

Fan Coil

# SILENCE THIN ETM - ETI

with Smart Touch controls

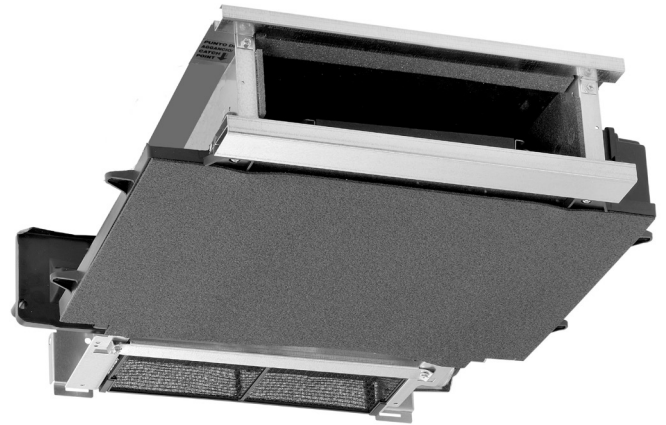

**GB** INSTALLATION AND USE MANUAL



**EMMETI**

CE





Thanks you for the trust you have shown by purchasing this product. Carefully read this manual which contains the specifications and all the information useful for the correct functioning.

The information contained in this publication may be subject to changes at any time and without any notice whatsoever for technical and/or commercial reasons as they arise; therefore, we cannot be held responsible for any errors or imprecisions contained herein.

© All rights reserved. No part of this publication may be reproduced or distributed without written permission from Emmeti.

**Warning!**

Keep these manuals in a dry place avoiding in this way to spoil them.

## INDEX

- |   |   |   |
|---|---|---|
| <p><b>P. 4 Premise</b></p> <p><b>P. 5 Overview</b></p> <ul style="list-style-type: none"> <li>- General Information</li> <li>- Conformity</li> <li>- Symbols</li> </ul> <p>General warnings<br/>basic safety<br/>rules</p> <p><b>P. 6 Product range</b><br/><b>Getting to know Thin</b></p> <p><b>P. 7 Overall dimensions</b><br/><b>2-pipe THIN</b></p> <p><b>P. 8 Technical specifications</b><br/><b>2-pipe THIN version</b></p> <p>installation</p> <ul style="list-style-type: none"> <li>- POSITIONING THE UNIT</li> <li>- INSTALLATION METHOD</li> </ul> <p><b>P. 9 Minimum distances for</b><br/><b>installation</b></p> <ul style="list-style-type: none"> <li>- Opening the sides</li> </ul> <p><b>P. 10 Upright floor or wall-mounted</b><br/><b>installation</b></p> <p><b>P. 11 Horizontal or ceiling-mounted</b><br/><b>installation</b></p> <ul style="list-style-type: none"> <li>- Hydraulic connections</li> </ul> <p><b>P. 12 Connections</b></p> <ul style="list-style-type: none"> <li>- Condensate drain</li> </ul> <p><b>P. 13 Fitting the condensate drain</b><br/><b>device in the vertical</b><br/><b>version</b></p> <p><b>P. 13 Fitting the condensate drain</b><br/><b>device in the horizontal</b><br/><b>version</b></p> <p><b>P. 14 Rotating the connections</b></p> <ul style="list-style-type: none"> <li>- Disassembling the panelling</li> <li>- Disassembling the control<br/>panel (if present)</li> <li>- Disassembling the heat<br/>exchangers</li> </ul> | <p><b>P. 17 Fitting the front grid</b><br/><b>safety support</b></p> <p><b>P. 18 Filling the system</b></p> <p><b>P. 18 Evacuating the air</b><br/><b>while filling</b><br/><b>the system</b></p> <p><b>P. 18 Maintenance</b></p> <ul style="list-style-type: none"> <li>- external cleaning</li> <li>- cleaning the air<br/>intake filter</li> </ul> <p><b>P. 21 Anomalies and solutions</b></p> <p><b>P. 22 Hydraulic kit</b><br/><b>fitting components</b><br/><b>list of hydraulic accessories</b></p> <ul style="list-style-type: none"> <li>- types of hydraulic connections</li> <li>- piping diameter</li> <li>- opening the sides</li> </ul> <p><b>P. 23 Adjusting the retainer</b></p> <p><b>P. 23 3-Way Valve With Diverter</b><br/><b>Valve Thermoelectric</b><br/><b>Head Kit</b></p> <p><b>P. 24 ETM, ETI version, with</b><br/><b>3-way diverter valve</b><br/><b>fitting the thermostatic</b><br/><b>head</b></p> <p><b>P. 25 Graphics</b></p> <p><b>P.36 THIN-4-V electric box</b><br/><b>Assembly</b></p> | <p><b>P. 38 THIN-TBK electric box</b><br/><b>Assembly</b></p> <p><b>P.54 THIN-4-V electric box</b></p> <p><b>P.57 Technical data</b></p> <p><b>P.58 Assembly template</b></p> |
|---|---|---|

## 1. Foreword

**In order to ensure safe, correct use of the unit, the installer, the user and the maintenance technician are required to carefully adhere to the provisions of this manual.**





Keep this booklet in a dry place, to avoid damage to it, for at least ten years, for possible future reference.

- **Carefully read all of the information in this booklet:** they provide important information on safe installation, use, and maintenance.
- **Pay particular attention to the instructions for use accompanied by the captions "DANGER" or "ATTENTION", since, if not obeyed, they can cause damage to the unit and/or persons or property.**
- In the event of any problems not covered by this booklet, contact the Technical Assistance Service in your area promptly.
- Make sure that this booklet always accompanies the unit.
- This booklet constitutes an integral and essential part of the product and must be delivered to the user.
- In the event that the unit is sold, or transferred to another owner, always make sure that the booklet accompanies the unit so that it can be consulted by the new owner and/or by the installer.
- **The manufacturer declines all responsibility for damage arising from improper use of the unit, or from a partial or superficial reading of the information contained in the booklet.**
- The technical data, the aesthetic characteristics, the components and the accessories listed in this booklet are not binding. The manufacturer reserves the right to introduce at any time all the modifications believed to be necessary for the improvement of its product.
- References to laws, standards or technical regulations cited are to be understood to be for information only and to refer to their publication

date. The coming into force of new provisions, or of modifications to those in force, shall not be a ground for obligation by the manufacturer towards third parties.

- The manufacturer is responsible for the compliance of its product with laws, regulations and standards of construction in force at the time of marketing. Knowledge and observance of the legislative provisions and standards applying to the design of the equipment, its installation, use and maintenance are the exclusive responsibility, as regards their respective capacities, of the designer, the installer and the user.
- **ATTENTION! It is important to check that the design and the installation conform to current standards (EN Standards, safety rules and local regulations) and are approved, where applicable, by the competent regulating bodies on the subject.**

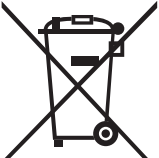
## Directive 2012/19/EC (RAEE)

    	<p>At the end of its operating life the UTA serie unit must be disposed according to the regulation in force in the installation country.</p> <p>The units are manufactured with the following materials:</p> <ul style="list-style-type: none"> <li>- Plates</li> <li>- Copper – Aluminium - Stainless steel</li> <li>- Polyester – Polyethylene - Fiberglass - Plastic</li> </ul> <p>This product is in compliance with the EU 2002/96/EC Directives. The symbol of the crossed-out rubbish bin shown on the appliance indicates that at the end of its useful life, since it is handled separately from domestic waste, the product must be sent to a separate waste collection centre for electric and electronic appliances or returned to the retailer at the moment of purchase of a new equivalent appliance.</p> <p>The user is responsible for sending the product to a suitable collection centre at the end of its life cycle. Proper separate collection for subsequent recycling of the de-commissioned appliance, its handling and environmentally friendly disposal, helps to prevent possible negative effects on the environment and public health and favours the recycling of the product's manufacturing material. For more detailed information about available collection systems, refer to the local waste disposal services or the shop where you bought the appliance.</p>
---	--

## OVERVIEW

### GENERAL INFORMATION

Thank you for choosing an EMMETI Thin fan coil unit to air condition your rooms. Please read this user and installation manual carefully before installing and operating the appliance. By following the suggestions below you will be able to maintain the performance of the appliance over time. In compliance with European regulation 99/44/EEC, the manufacturer guarantees the machine for 24 months from the date of purchase (without prejudice to any commercial warranty extensions), for any manufacturing defects. Any other problem related to incorrect installation, extraordinary weathering, non-conforming sizing and unauthorised tampering is excluded.

### Conformity

EMMETI Thin fan coil units conform to European Directives:

- Low Voltage Directive (LVD) 2014/35/EU;
- Electromagnetic compatibility Directive (EMC) 2014/30/EU;
- RoHS Directive 2011/65/EC
- WEEE Directive 2012/19/EU

### Symbols



The pictograms shown in the following chapter allow you to provide information, quickly and unequivocally, which is necessary for the machine to be used correctly and safely.

### Index

- The paragraphs preceded by this symbol contain crucial information and prescriptions, regarding safety in particular. Failure to comply may result in:
  - risks for operator safety
  - loss of the warranty
  - disclaimed liability by the manufacturer.

### General hazard

- if the operation described is not performed in compliance with safety regulations, there may be a risk of suffering physical damage.



### Electrical hazard

- if the operation described is not performed in compliance with the safety regulations, there lies the risk of suffering physical damage due to contact with live elements.



### GENERAL WARNINGS

After unpacking, check that the contents are intact and that all parts are included. If not, contact EMMETI who sold the appliance to you.

#### The packaging contains:

- fan coil unit
- thermal insulation for valve and retainer
- 2 brackets
- user and installation manual
- paper template.

The appliance must be installed by an authorised EMMETI. Once the work is done, it must issue a declaration of conformity to the client in compliance with current regulations and with the indications in the instruction manual supplied by the manufacturer with the appliance.

These appliances have been designed for conditioning and/or heating rooms and they must be destined solely for this purpose, in accordance with their performance characteristics.

The manufacturer refuses any contractual or extra-contractual liability for damage caused to people, animals or property resulting from incorrect installation, adjustment, maintenance or improper use.

In the event of water leaks, turn off the main switch and close the water taps. Immediately call the Technical Assistance Service EMMETI or other qualified personnel and do not intervene personally on the appliance.

The recessed ETI series THIN have no grids or a cover cabinet. Provide protective elements and air supply/return grids to prevent accidental contact with the appliance.

The following steps must be carried out if the appliance is not to be used for a long period:

- Set the master switch of the system to "off"
- Close the water valves
- If there is a risk of frost, make sure that antifreeze liquid has been added to the system, otherwise empty the system.

A temperature that is too high or too low is harmful to health and is an unnecessary waste of energy. Avoid prolonged direct contact with the air flow.

Do not leave the room closed for long. Periodically open the windows to ensure proper ventilation.

This instruction booklet is an integral part of the appliance and, therefore, it must be kept with care and must ALWAYS accompany the appliance, even when the latter is transferred to another owner or user or transferred to another system. If it gets damaged or lost, please request another copy from the local Technical Assistance Service.

Repairs or maintenance must be performed by the Technical Assistance Department or by skilled personnel in accordance with this manual.

Do not modify or tamper with the appliance as hazardous situations may be generated and the appliance manufacturer shall not be held liable for any damage caused.

### BASIC SAFETY RULES



The use of products that use electricity and water requires the observation of some fundamental safety rules such as:

Use of the appliance by children and unassisted disabled persons is prohibited.

It is forbidden to touch the appliance if you are barefoot or when parts of the body are wet or damp.

Any cleaning operation is prohibited before disconnecting the appliance from the mains power supply by placing the main system switch on "off".

It is forbidden to modify the safety or adjustment devices without the authorization and the manufacturer's directions unit.

It is forbidden to pull, disconnect or twist the electrical cables coming out of the appliance, even if it is disconnected from the mains.

It is forbidden to introduce objects and substances through the air intake and delivery grilles..

It is forbidden to open the access doors to the internal parts of the appliance, without having first placed the main system switch on "off".

It is forbidden to disperse and leave the packaging material within the reach of children as it can be potential source of danger.

It is forbidden to stand on the appliance and/or lean against it any type of object.

The appliance can reach temperatures on external components above 70 ° C

**BE VERY CAREFUL TO ANY CONTACT MADE, RISK OF BURNS.**



### PRODUCT RANGE

Fan coil units of the Thin range care are divided into 2 basic types: ETM and ETI – each of which has different performance and dimensions

#### ETM

fan coil unit (suitable for horizontal or vertical installations). The horizontal condensate drain pan kit accessories are available to install the ETM versions ETM BRC20 BRC40 BRC60 BRC80

#### ETI

recessed fan coil unit with no panelling (suitable for horizontal or vertical installations).

#### ATTENTION

It is understood that this equipment is not intended for use by persons (including children) with reduced physical, sensory or mental abilities and must not be used by people with no knowledge and experience of the product. They must be instructed and monitored while using the equipment by a person who is responsible for their safety.

**PRODUCT RANGE**

Fan coil units of the Thin range care are divided into 2 basic types: ETM and ETI – each of which has different performance and dimensions

**ETM**

fan coil unit (suitable for horizontal or vertical installations). The horizontal condensate drain pan kit accessories are available to install the ETM versions  
ETM BRC20 BRC40 BRC60 BRC80

**ETI**

recessed fan coil unit with no panelling (suitable for horizontal or vertical installations).

**ATTENTION**

It is understood that this equipment is not intended for use by persons (including children) with reduced physical, sensory or mental abilities and must not be used by people with no knowledge and experience of the product. They must be instructed and monitored while using the equipment by a person who is responsible for their safety.

**GETTING TO KNOW THIN**

THIN - 2-pipes fig. 1

**A - Bearing structure** in electro-galvanised sheet metal with high resistance.

**B - Water heat exchanger coil** in copper pipes and aluminium fins with high efficiency turbulence. Eurokonus 3/4 type threaded fittings, which conform to the new EU standardisation requirements.  
The coil is equipped with a sensor to detect the water temperature (ETM, ETI version, electronic).

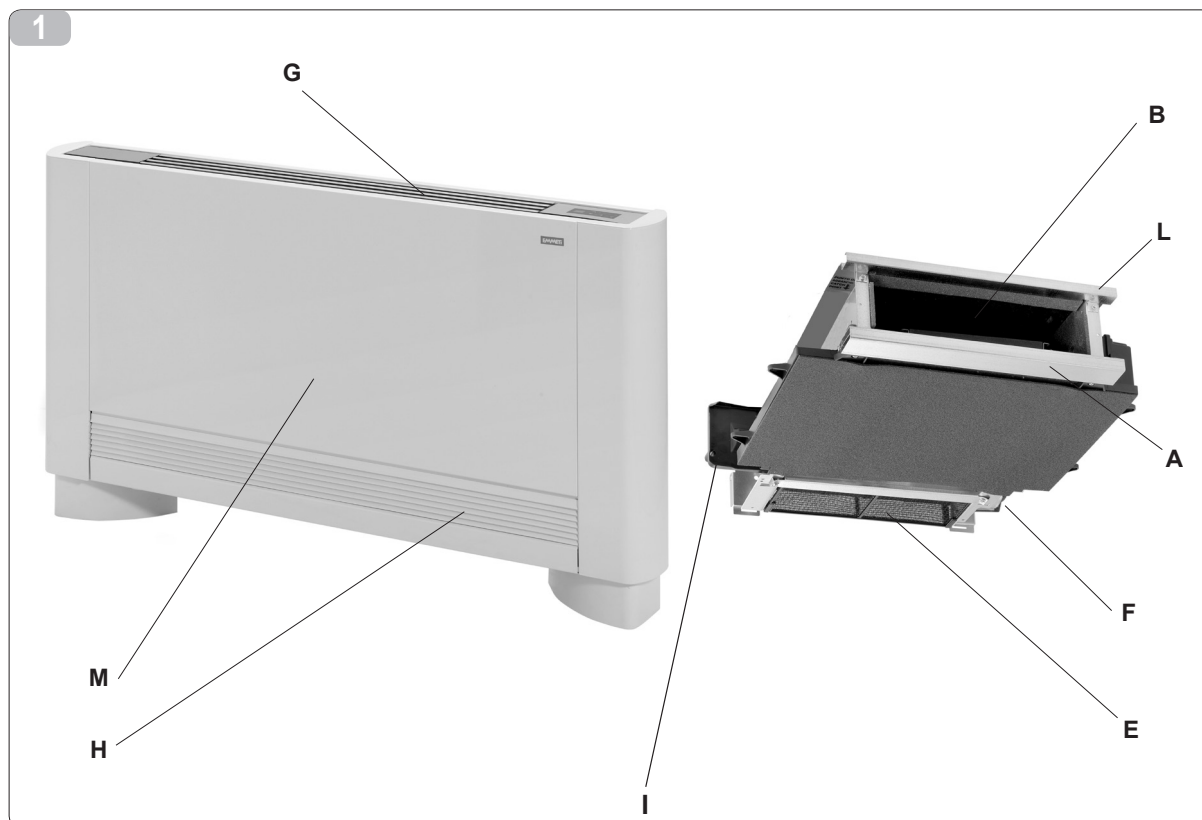

**E - Ventilation unit**

including a tangential fan in synthetic material with staggered fins (very quiet), fitted on EPDM anti-vibration mounts, statically and dynamically balanced, and fitted directly onto the crankshaft.

**F - Electric motor**

single-phase resin pack fitted on EPDM anti-vibration mounts.

**G - Reversible air supply grid**

in oven dried, epoxy powder coated aluminium (metallic silver). The large size enhances the high mechanical resistance.

**H - Intake air grid**

in electro-galvanised, oven-dried, epoxy powder coated sheet metal, with a quick release device for cleaning the filters and a safety microswitch.

**I - Condensate drain pan**

for vertical installation, in ABS, easily removable for cleaning operations. For ETM versions to be installed horizontally, the horizontal condensate drain pan kit (BRC) accessory is available.

**L - Back panel**

soundproofing structure in compressed yarn (FIMBORD GR900) with high resistance.

**M - Front casing**

and removable side panels in electro-galvanised, oven dried, epoxy powder coated sheet metal.

**2-PIPE THIN OVERALL DIMENSIONS**

See figure 3 and refer to the relevant model.

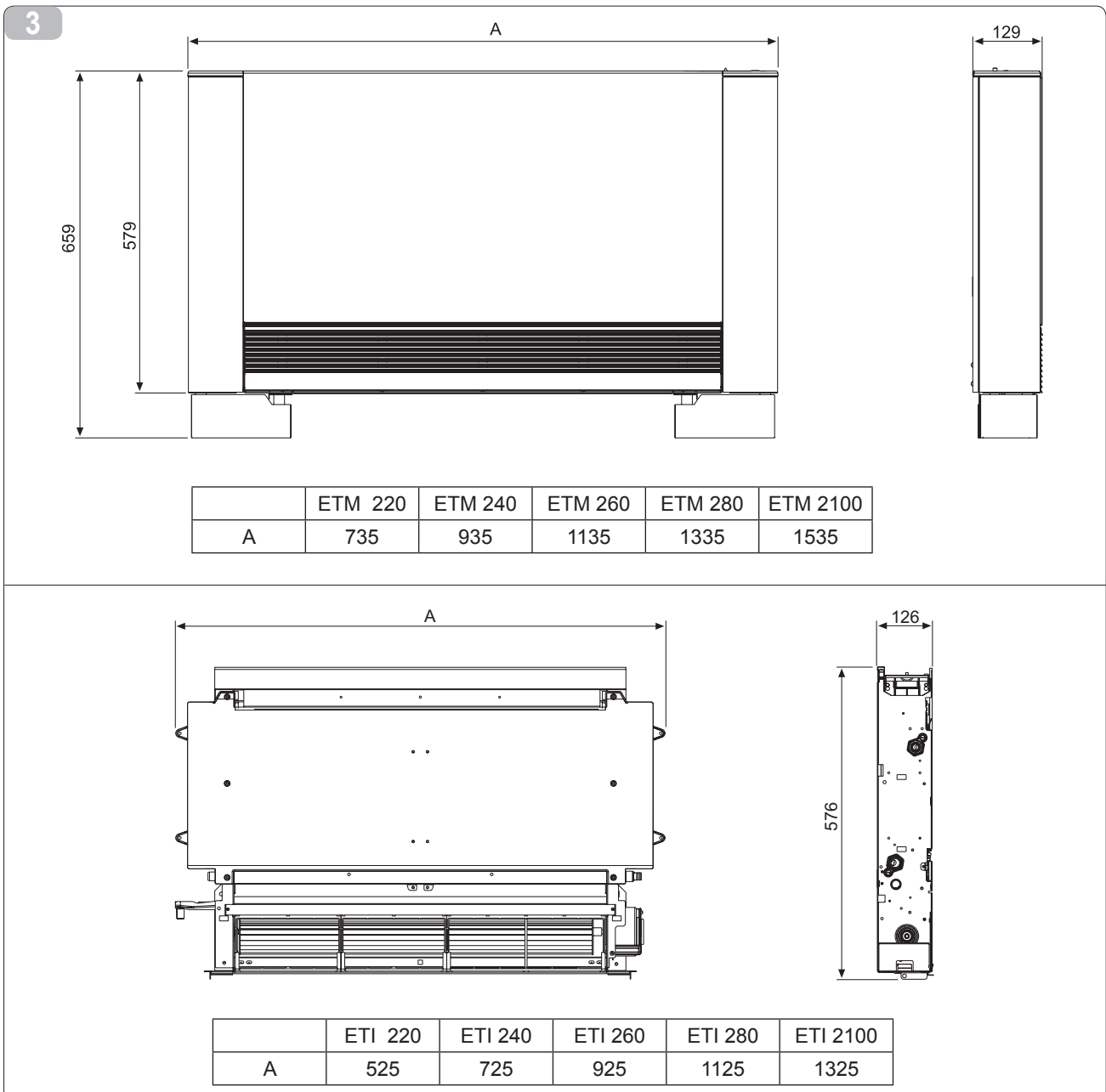

## 2-PIPE THIN VERSION TECHNICAL SPECIFICATIONS

See the table in figure 5 and refer to the relevant model.

- A** Coil water content
- C** Maximum operating pressure
- D** Maximum water inlet temperature
- E** Minimum water inlet temperature
- F** Hydraulic connections
- G** Supply voltage
- H** Absorbed max current
- I** Absorbed max power
- M** Weight of ETI
- N** Weight of ETM

5

MOD.		220	240	260	280	2100
<b>A</b>	ℓ	0.47	0.8	1.13	1.46	1.8
<b>C</b>	bar	10	10	10	10	10
<b>D</b>	°C	80	80	80	80	80
<b>E</b>	°C	4	4	4	4	4
<b>F</b>	"	Eurokonus 3/4	Eurokonus 3/4	Eurokonus 3/4	Eurokonus 3/4	Eurokonus 3/4
<b>G</b>	V/ph/Hz	230/1/50	230/1/50	230/1/50	230/1/50	230/1/50
<b>H</b>	A	0.11	0.16	0.18	0.26	0.28
<b>I</b>	W	11.9	17.6	19.8	26.5	29.7
<b>M</b>	kg	9	12	15	18	21
<b>N</b>	kg	17	20	23	26	29

### INSTALLATION

#### POSITIONING THE UNIT



##### Do not install the unit near:

- anything that is subject to direct exposure to sunlight;
- sources of heat;
- damp environments and areas with probable contact with water;
- environments with oil vapours
- environments subjected to high frequencies.

- the installation wall is possibly an external perimeter wall so as to allow the outward condensate drain;
- in case of a ceiling installation, the air flow is not directed directly towards people.

##### Make sure that:

- the wall on which the unit is to be installed has an adequate structure and capacity;
- the area of the wall in question has no pipes or electric lines passing
- the wall in question is perfectly level;
- there is an area free from obstacles, which could compromise the input and output air circulation;



### INSTALLATION METHOD

The following descriptions of the various assembly phases and the relative drawings refer to a machine version with connections on the left.

The descriptions for machine assembly operations with connections on the right are the same.

The images just have to be considered specular.

Carefully follow the instructions in this manual for a successful installation and optimal operating performance. Failure to apply the indicated standards, which can cause equipment malfunctions, relieve EMMETI from any form of warranty and from any damage caused to people, animals or property.

It is important for the electrical installation to be executed in accordance with the law, for it to conform to the data indicated in the technical data sheet and for it to consist of a good earthing system.

The appliance must be installed in a position that easily allows routine (filter cleaning) and special maintenance to be performed, as well as access to the air vent valves (coil and plates), which can be reached from the top grid on the connections side.



**MINIMUM DISTANCES FOR INSTALLATION**

Figure 7 shows the minimum assembly distances of the fan coil unit from the walls and furniture in the room.

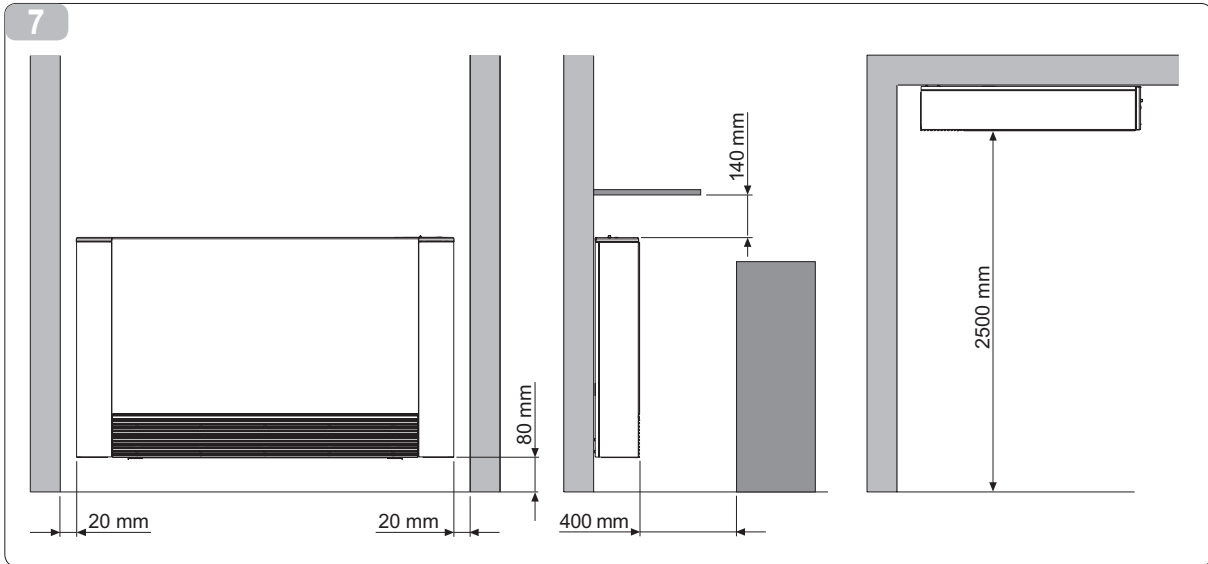

**OPENING THE SIDES**

- On the left side, lift the lid that covers the screw, loosen the screw that secures the left panel, move it slightly to the left and lift it.
- On the opposite side, lift the lid that covers the screw and unscrew it.
- Move the side panel slightly to the right and lift it.

A	lid
B	fixing screws
C	left panel
D	right panel

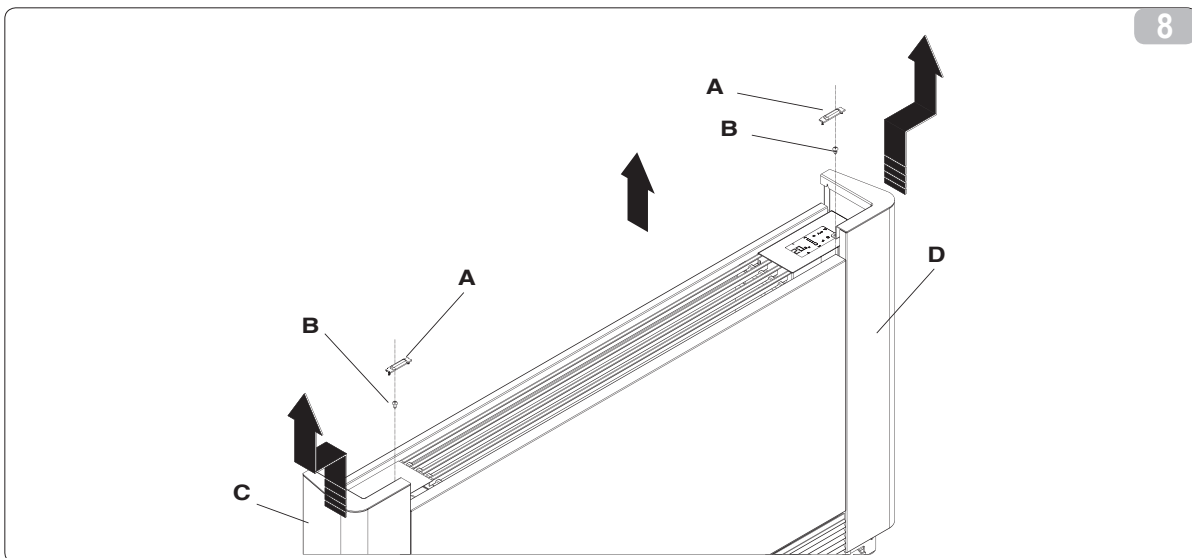

**WALL OR VERTICAL FLOOR INSTALLATION**

In the case of floor mounting with sockets, for mounting these, refer to the individual instruction sheets supplied and the relative manual.

Use the paper template, and trace the position of the two fixing brackets on the wall (fig. 9). Drill with a suitable tip and insert the dowels (2 for each bracket) (fig. 10 ref. A); fix the two brackets (fig. 10 ref. B). Do not over tighten the screws, so as to be able to adjust the brackets with a level bubble (fig. 11).

Lock the two brackets definitively by tightening the four screws completely. Check its stability by manually moving the brackets to the right and left, up and down.

Assemble the unit, checking the correct hooking on the brackets and its stability (fig. 12).

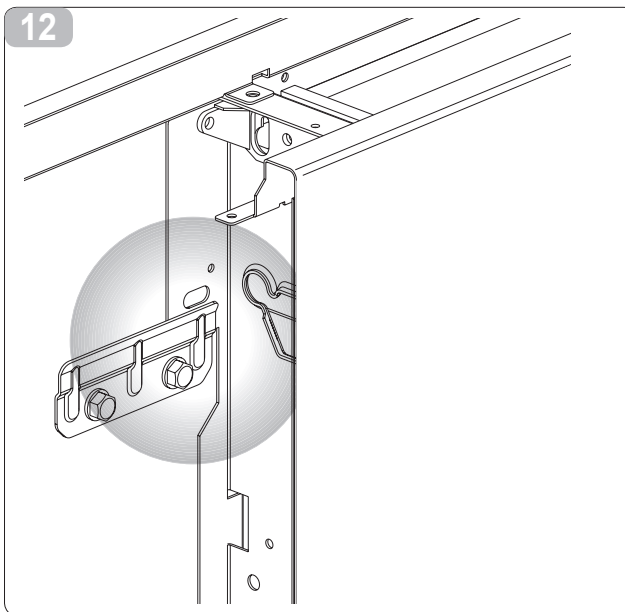
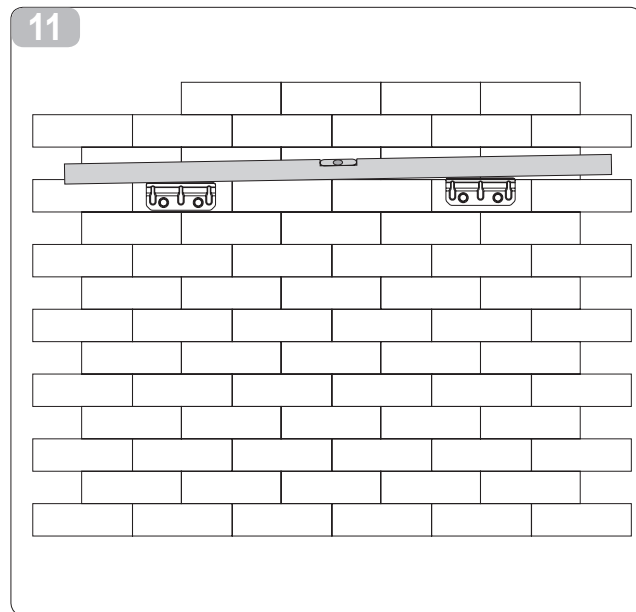
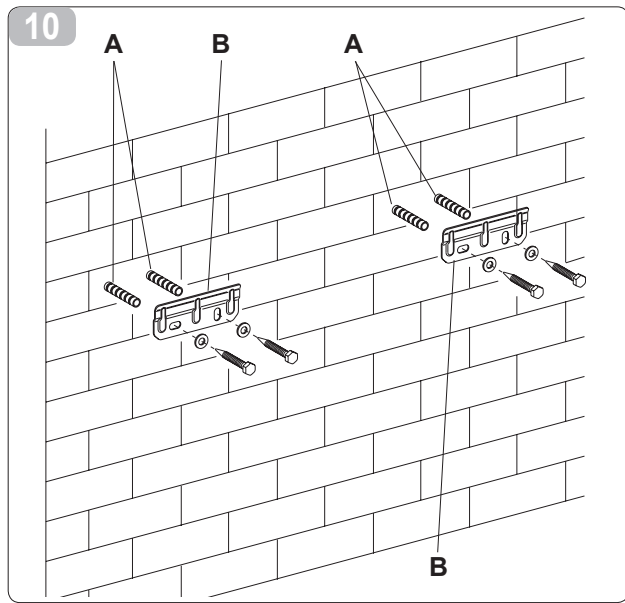
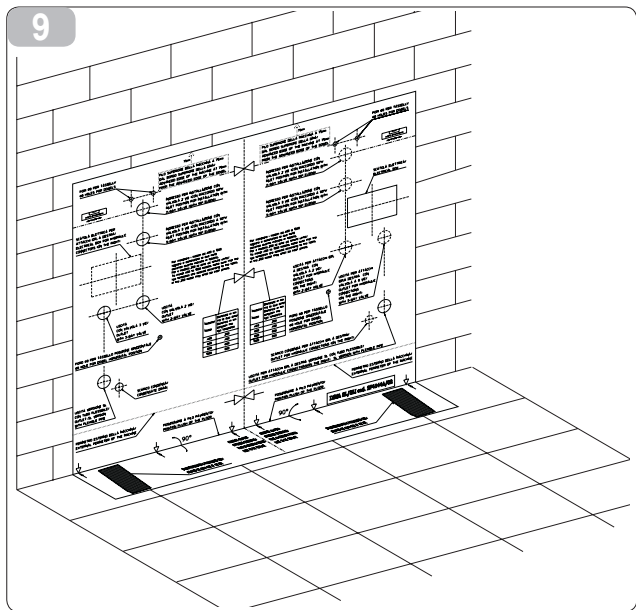

**HORIZONTAL OR CEILING-MOUNTED INSTALLATION**

Use the paper template to trace the position of the two fixing brackets and the two rear screws on the ceiling. Use a suitable tip to drill and insert the plugs (2 for each bracket) (fig. 13 ref. A); secure the two brackets (fig. 13 ref. B). Do not over tighten the screws.

Insert the machine on the two brackets, keeping it in position, then secure the two screws in the rear plugs (fig. 13 ref. C), one on each side.

It is recommended to apply an adequate inclination to the unit towards the drain pipe, so as to facilitate the water output (fig. 13 ref. D).

Tighten all 6 fixing screws securely.

The horizontal condensate drain pan kit accessories are available to install the ETM versions  
ETM BRC20 BRC40 BRC60 BRC80 BRC100.

**HYDRAULIC CONNECTIONS**  
Piping diameter

The minimum internal diameter that is to be complied with for the hydraulic connection pipes varies, according to the model:

<b>ETM-ETI 220</b>	<b>ø12 mm</b>
<b>ETM-ETI 240</b>	<b>ø14 mm</b>
<b>ETM-ETI 260</b>	<b>ø16 mm</b>
<b>ETM-ETI 280</b>	<b>ø18 mm</b>
<b>ETM-ETI 2100</b>	<b>ø20 mm</b>

For the position of the pipes for the wall-mounted connections, refer to the drawings in the following paragraphs, based on the specific configuration.

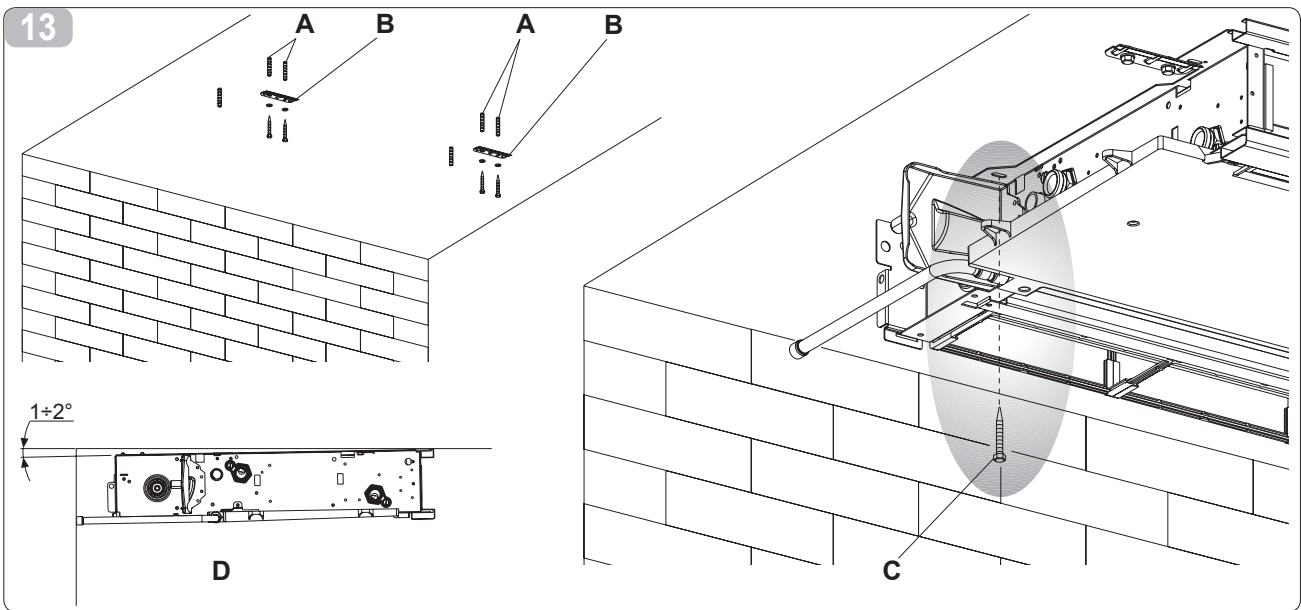

**CONNECTIONS**

The choice and sizing of the hydraulic lines is the responsibility of the designer, who must operate according to the rules of good technique and current legislation.

To make connections:

- position the hydraulic lines
- tighten the connections using the “key against key” method (fig. 14 ref. B)
- check for liquid leakage
- coat the connections with insulating material (fig. 14 ref. C).

Hydraulic lines and joints must be

thermally insulated.

Avoid partial pipe insulation.

Avoid tightening too much to avoid damaging the insulation.

For the water resistance of the threaded connections use hemp and green pasta; the use of Tef-

lon tape is recommended in the presence of antifreeze liquid in the hydraulic circuit.

14

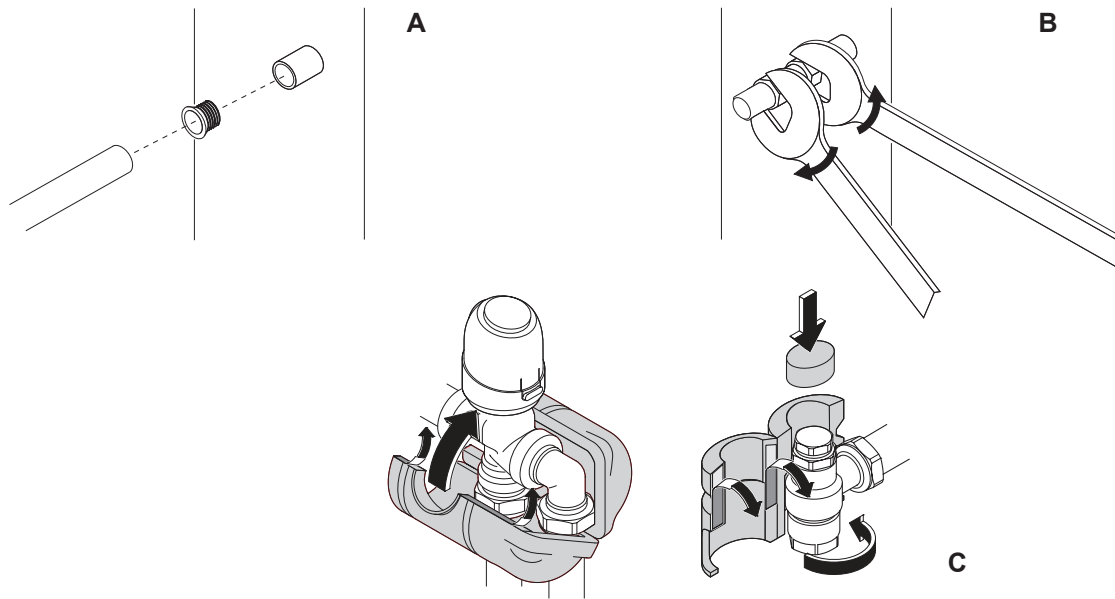

**CONDENSATE DRAIN**

The condensate drain system must be adequately sized (minimum internal pipe diameter 16 mm) and the piping positioned so as to always maintain a certain gradient along the path, which is never less than 1%. When installed vertically, the drain pipe is connected directly to the drain pan, found at the bottom, on the side edge, under the hydraulic connections. In the horizontal installation, the drain pipe is connected to that already found on the machine. For the ETM versions to be installed horizontally, the ETM BRC20 /BRC80 horizontal

condensate drain pan kit accessories are available.

- If possible, drain the condensate liquid directly into a gutter or a rainwater drain.
- If drained into the sewer system, it is advisable to install a siphon to prevent the backflow of odours towards the rooms. The curve of the siphon must be lower than the condensate drain pan.
- Should the condensate have to be drained into a container, this must be left open and the pipe must not be immersed in the water, thereby preventing

phenomena related to adhesion and counter pressure that would hinder the free flow.

- A pump must be installed to overcome unevenness, which would obstruct the flow of condensate:
  - in a vertical installation, install the pump under the side drain pan;
  - in a horizontal installation, the position of the pump must be decided upon according to specific requirements.

**However, at the end of the installation, it is advisable to verify the correct outflow of the condensate liquid by pouring about 1/2 l of water very slowly (in about 5-10 minutes) into the drain pan.**

### FITTING THE CONDENSATE DRAIN DEVICE IN THE VERTICAL VERSION

Connect the condensate drain pan fitting (fig. 15 ref. A) to a pipe for the flow of liquid (fig. 15 ref. B) and block it properly. Check that the drip guard extension (fig. 15 ref. C) is present and installed correctly.

### FITTING THE CONDENSATE DRAIN DEVICE IN THE HORIZONTAL VERSION

Refer to the instructions found in the BRC20/BRC100 kits to install the horizontal pan on the ETM versions.

- check that the L-shaped pipe and the flexible rubber pipe are connected correctly to the pan (fig. 16 ref. A).
- insert the side of the machine while keeping the pipe in position, in abutment on the front grid.
- close the side securely, checking that the pipe remains blocked in the specific slot on the side (fig. 16 ref. B).

**NOTE:** abide by the following warnings for a horizontal installation:

- make sure the machine is installed perfectly level, or with a slight inclination towards the condensate drain;
- insulate the supply and return pipes well, up to the inlet to the machine, so as to prevent condensation from dripping outside the drain pan;
- insulate the condensate drain pipe of the pan along its entire length.

15

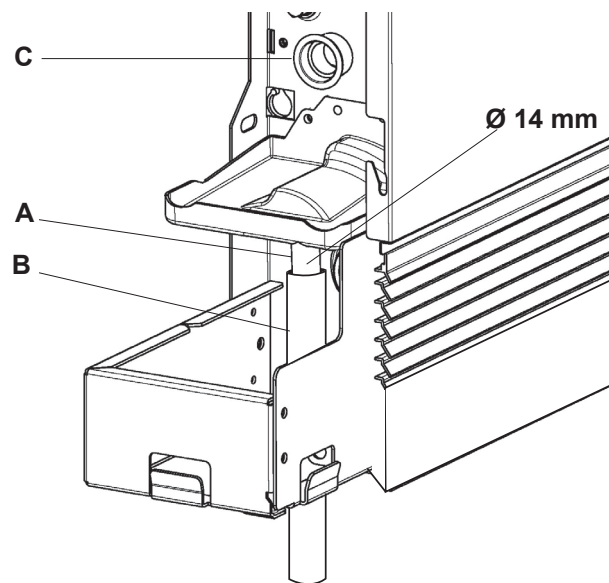

16

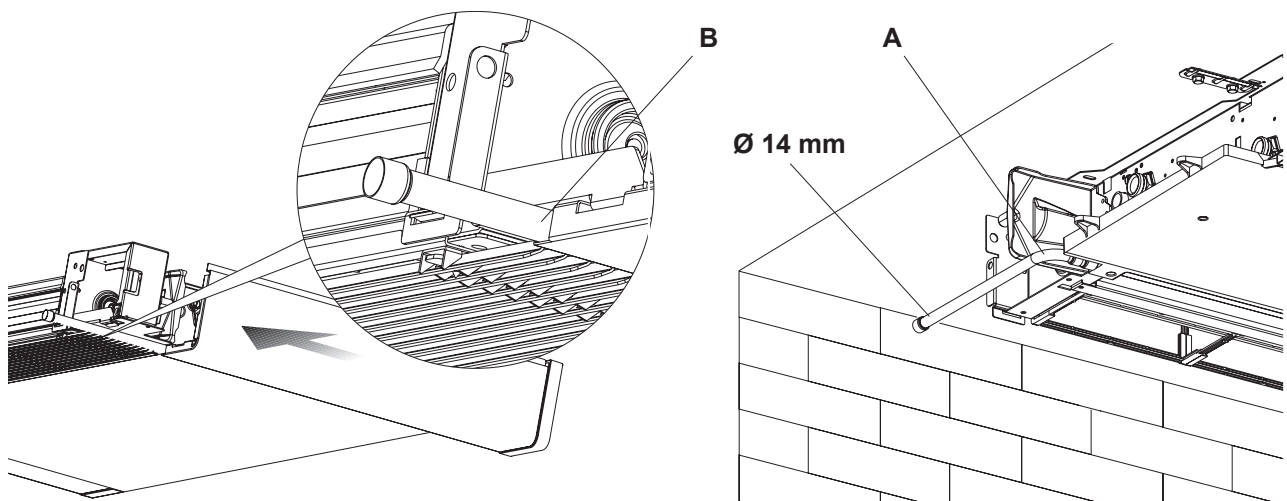

**ROTATING THE CONNECTIONS**



Pay particular attention to all steps to rotate the exchanger connections so as to prevent water leaks and malfunctions.

The steps described and the relative images refer to a machine with connections on the left, which require the rotation of the connections on the right side. If you have a machine with connections on the right that need to turn to the left, the sequence is the same, the

images just have to be considered specular.  
Connect the motor to the control kits by using the relevant optional CCM-DC wiring cod.07524061.

**Disassembling the panelling**

- Remove the upper grid (fig. 17 ref. E) by unscrewing the two fixing screws (fig. 17 ref. F).

- On the left side, lift the lid that covers the screw, loosen the screw that secures the left panel, move it slightly to the left and lift it.
- On the opposite side, lift the lid that covers the screw and unscrew it.
- Move the side panel slightly to the right and lift it.

A	lid
B	fixing screws
C	left panel
D	right panel

- Remove the lower front grid (fig. 18 ref. A).
- Unscrew the front panel (fig. 18 ref. E) fixing screws (fig. 18 ref. B-D) and remove it.

17

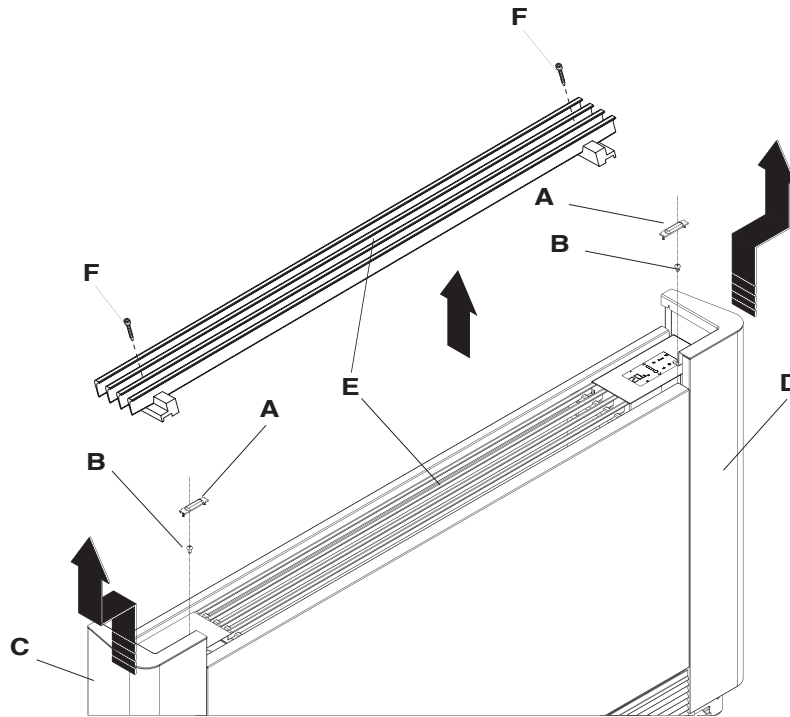

18

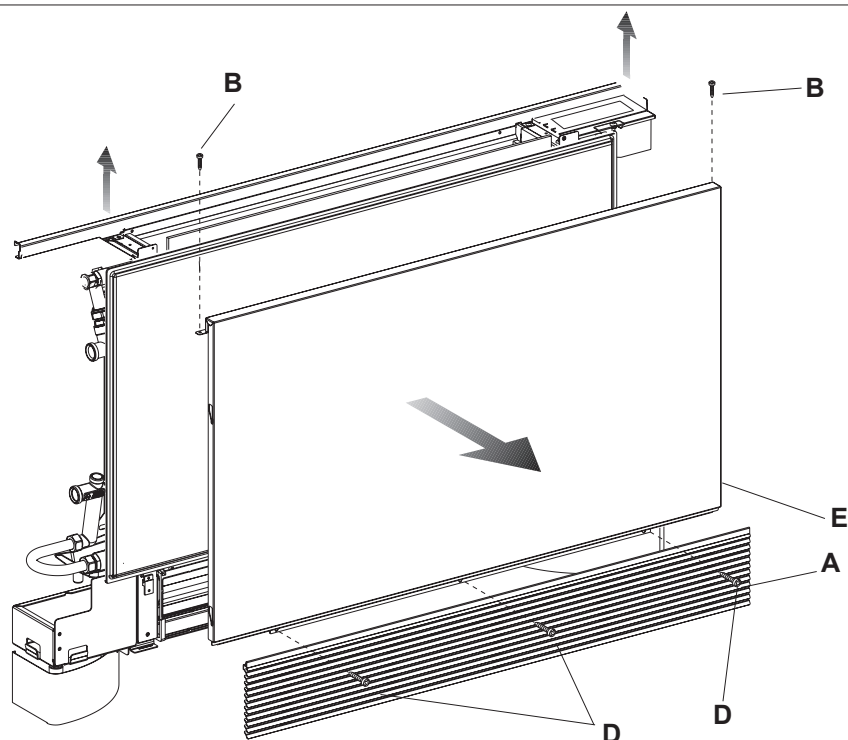

### Panel disassembly of command (if present)

- Set the system main switch to off.
- Remove the two screws that fix the blind panel (fig. 20 ref. A) to the front panel (fig. 18 ref. E).
- Remove the two screws that fix the control panel (fig. 20 ref. C) to the front panel (fig. 18 ref. E).
- Remove the electrical panel on the side of the fan coil unit and then place it on the opposite side.
- Disconnect the electrical connection connectors.
- Remove the wiring inside the machine and reinsert them from the opposite side.
- Use the appropriate CCM-DC wiring for right-hand connections cod.07524061 for the motor connection, available as an accessory.
- Reverse the mounting positions (fig. 20 ref. C) of the control panel and remount them in their respective positions.
- Remove the condensate collection tray (fig. 20ref. F) and refit it on the opposite side with the relative fixing screws (fig. 20 ref. G).

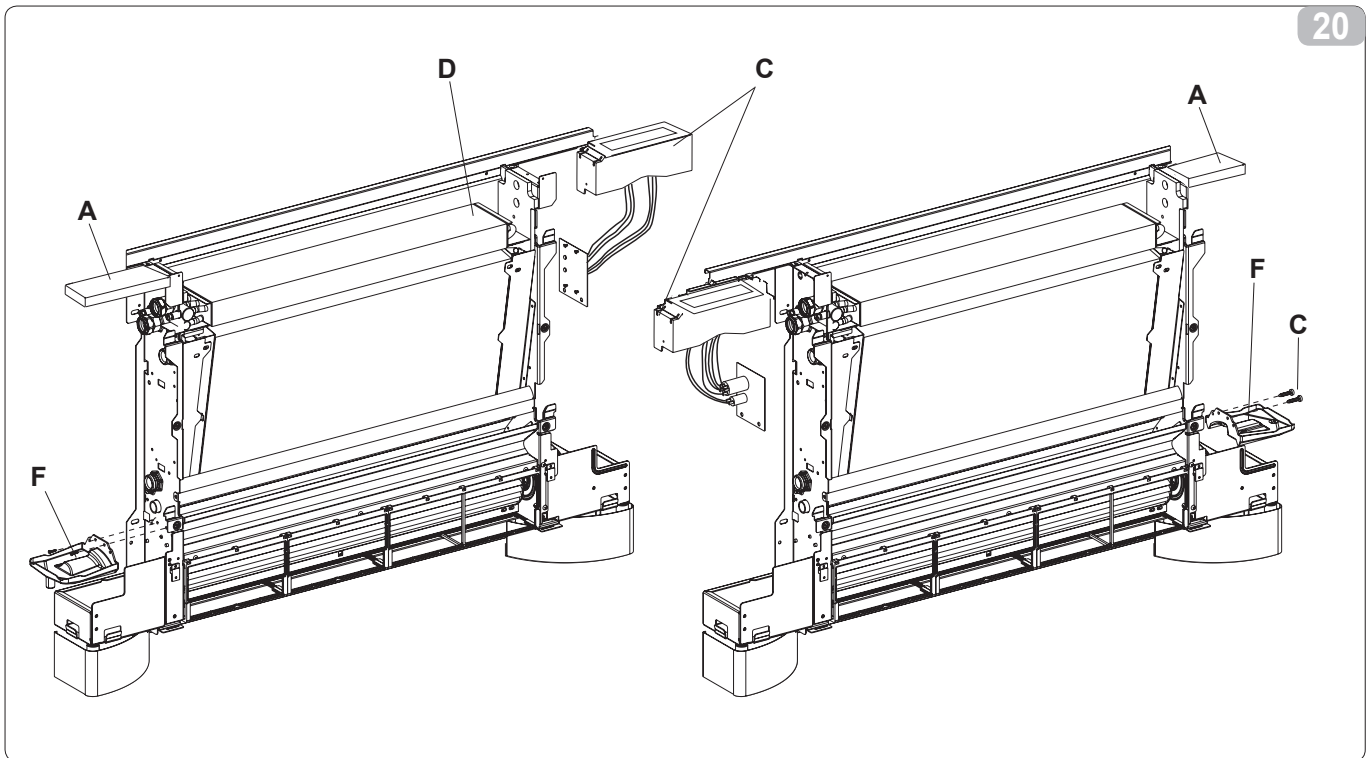

20

**Disassembling the heat exchangers**

- Unscrew the four screws that secure the heat exchanger (fig. 21 ref. C);
- remove the coil water probe, if present.
- remove the heat exchanger (fig. 21 ref. F);
- remove the drip guard extension from the central pan (fig. 21 ref. D);
- on the opposite side, remove the plug on the condensate evacuation hole (fig. 21 ref. E);
- unscrew the fixing screw of the central condensate drain pan (fig. 21 ref. G), set the pan on the opposite side so that the connection nozzle for the drip guard extension comes out of the structure, therefore block the pan with the previously removed screw;
- reinsert the drip guard extension and the cap on the opposite side;
- open the pre-cut hexagonal holes on the right side insulation and close the hexagonal holes on the left edge with insulating material;
- rotate the exchanger, bringing the connections to the opposite side, and reinsert it on the machine (fig. 22);
- tighten all the heat exchanger fixing screws.

Once all the described steps have been completed, reassemble all the previously disassembled components, following the disassembly steps in inverse order.

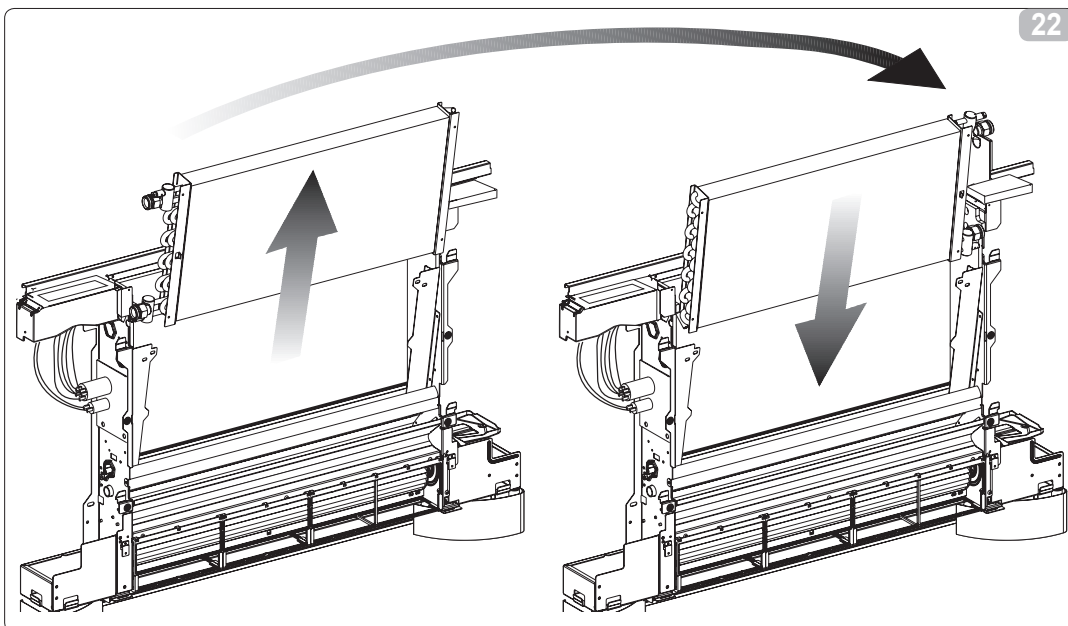
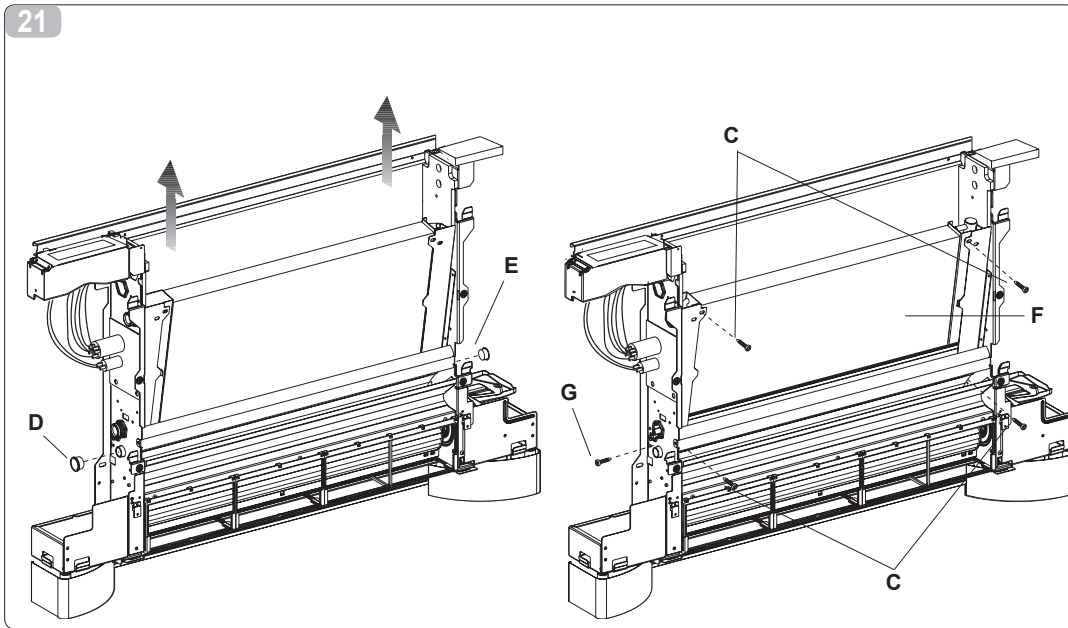



## FITTING THE FRONT GRID SAFETYSUPPORT

If the fan coil unit is installed in a horizontal position, ensure the filter cleaning/replacement steps are carried out safely, the two safety clamps found in the bag provided with the instruction manual and accessories, **must** be installed by the installer.

- Separate the two clamps (fig. 24 ref. A);
- open the front grid and unscrew the fixing screws of the springs completely (fig. 24 ref. B);
- secure the two clamps by retightening the screws (fig. 24 ref. B);
- secure the other part of the clamps to the grid using the screws supplied (fig. 24 ref. C);
- close the grid.

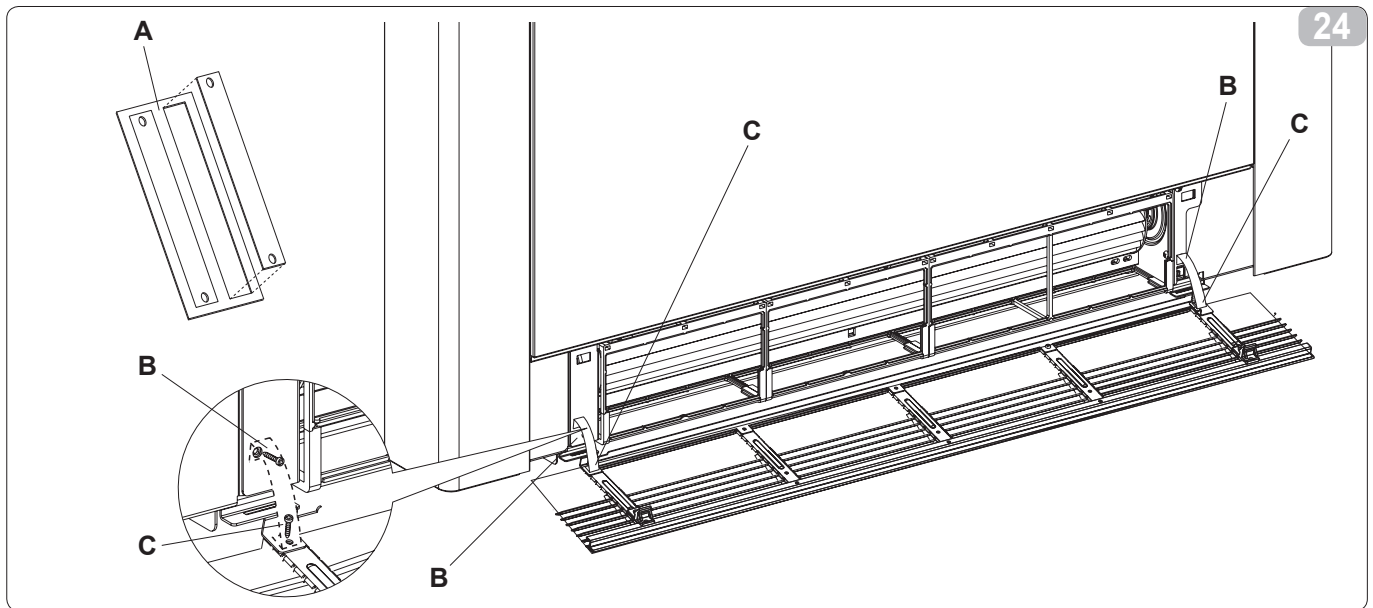

**SYSTEM FILLING**

When starting up the system, make sure that the holder on the hydraulic unit is open. If you find yourself without a power supply and the thermo-valve  
It has already been powered previously. You will need to use the special cap to press the valve shutter to open it.

**EVACUATION OF THE AIR DURING THE FILLING OF THE SYSTEM**

- Open all the system interception devices (manual or automatic);
- Start filling by slowly opening the system water filling tap;
- For the ETM and ETI models installed in a vertical position act (using a screwdriver) on the top of the battery vent (fig.25 ref.A); for appliances installed in a horizontal position, act on the topmost vent (fig.25 ref.B);

- When water starts coming out of the vent valves of the appliance, close them and continue loading up to the intended nominal value for the system.

Check the hydraulic tightness of the gaskets.

It is advisable to repeat this step after the appliance has been running for a few hours and to regularly check the system pressure.

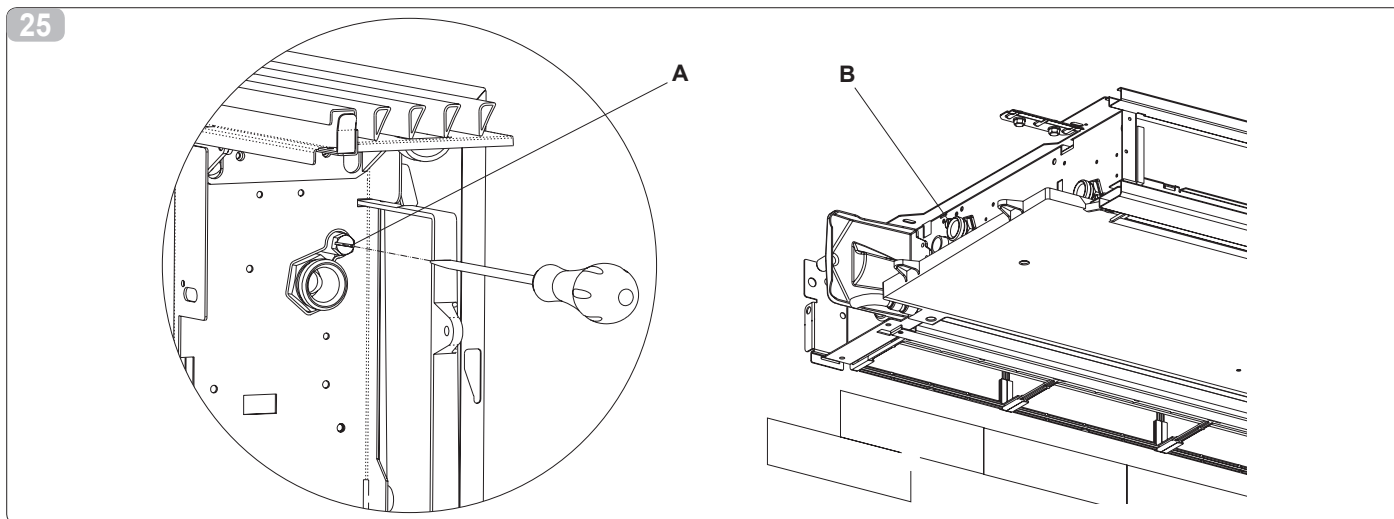

**MAINTENANCE**

Periodic maintenance is essential to maintain the SILENCE - THIN fan coil unit always efficient, safe and reliable over time. Certain steps can be performed half-yearly, and other annually, by the Technical Assistance Department, which is technically authorised and trained, and can also dispose of original spare parts, if necessary.

**EXTERNAL CLEANING**



**Before performing any cleaning or maintenance, disconnect the unit from the mains by switching off the main power switch.**



**Wait for the components to cool down so as to prevent the risk of burns.**

When necessary, clean the external surfaces of the SILENCE - THIN fan coil unit with a soft cloth dampened with water (fig. 28).



**Do not use abrasive sponges or abrasive or corrosive detergents so as not to damage the painted surfaces.**

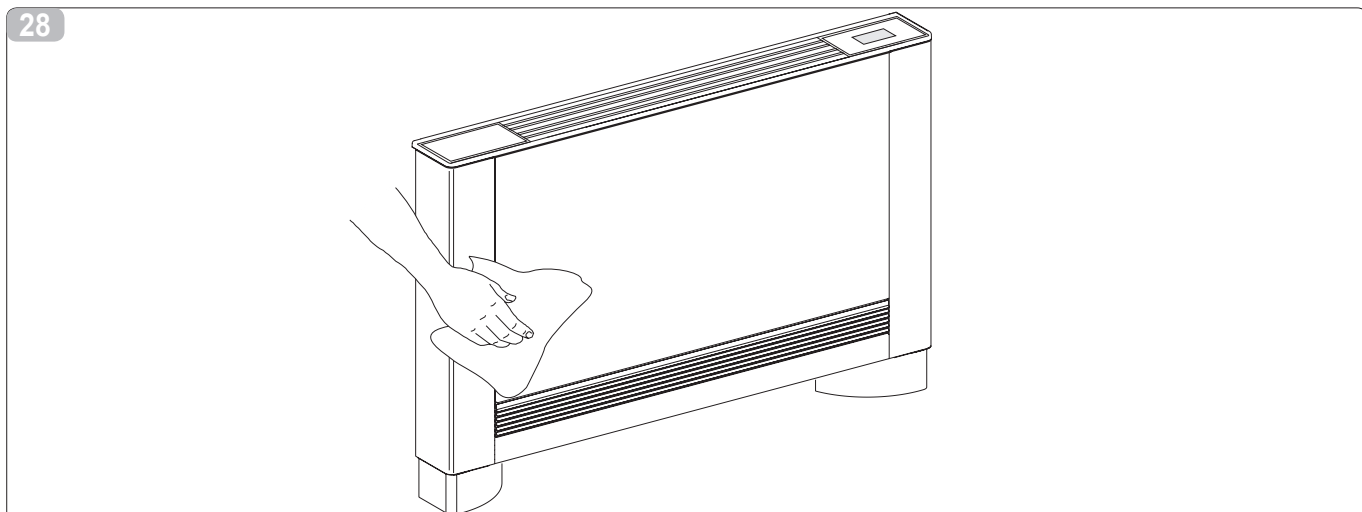

### Air intake filter cleaning

After a period of continuous operation and in consideration of the concentration of impurities in the air, or when you intend to restart the system after a period of inactivity, proceed as described.

Extraction of filter cells in the versions with fin suction grille

- remove the front grille by lifting it slightly (fig. 29 ref. A) and rotate it until it is completely out of its seat (fig. 29 ref. B);
- remove the filter (fig. 29 ref. C), pulling it horizontally outwards (fig. 29 ref. D).

#### Cleaning filter media

- vacuum the dust from the filter with a vacuum cleaner (fig. 31 ref. A)
- wash the filter (fig. 31 ref. B) under running water, without using detergents or solvents, and allow it to dry.
- Reassemble the filter on the fan coil (fig. 32 ref. A), paying particular attention to insert the lower edge (fig. 32 ref. B) in its seat (fig. 32 ref. C).



- It is forbidden to use the appliance without the mesh filter.



- The appliance is fitted with a safety switch that prevents the fan from running without the intake grid or if it is set incorrectly.



- After cleaning the filter, check that the intake grid is installed correctly.

#### Complete the cleaning steps

- For the versions with a finned grid, insert the two tabs (fig. 33 ref. A) into the relevant slots (fig. 33 ref. B), rotate it and engage it with a slight knock on in the upper part.

#### TIPS TO SAVE ENERGY

- Always keep the filters clean;
- keep doors and windows of the rooms that are to be air-conditioned closed as much as possible;
- in the summer, limit the direct irradiation of the sunrays into the areas that are to be air-conditioned, as much as possible (use curtains, shutters, etc.).

29

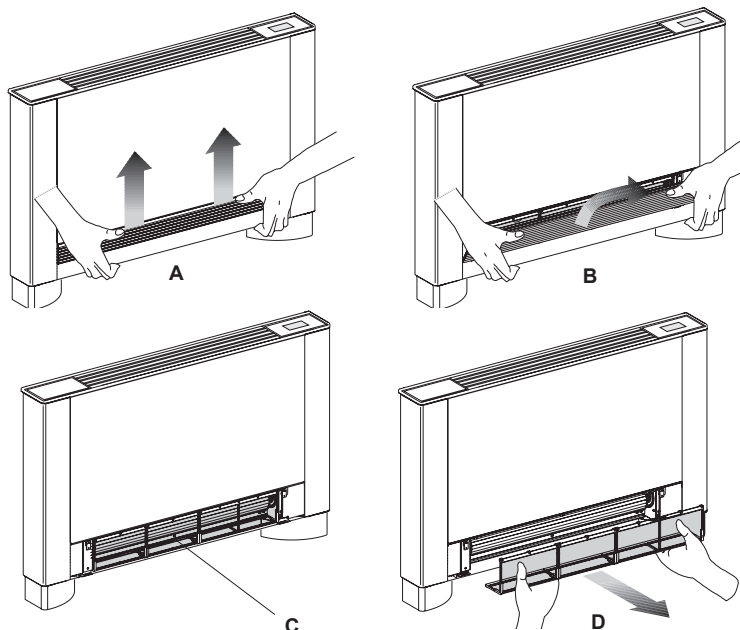

31

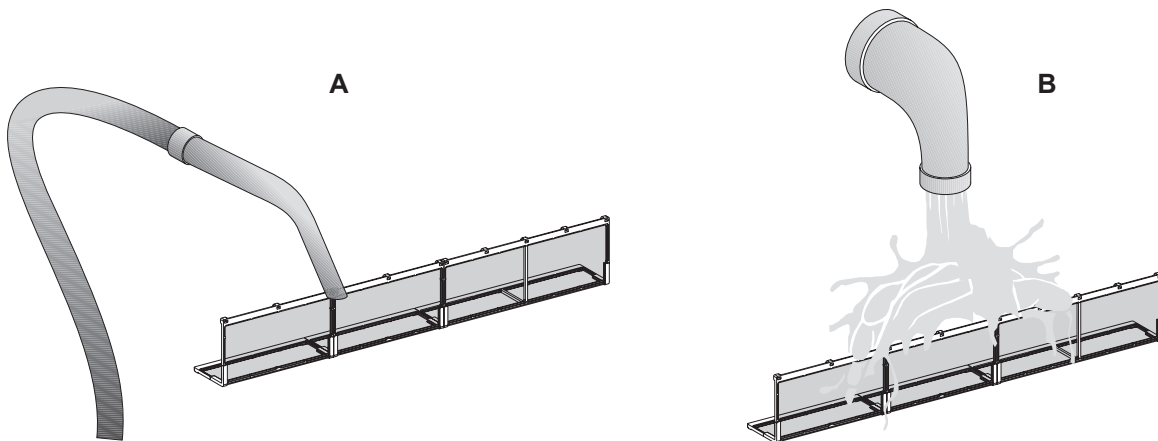

32

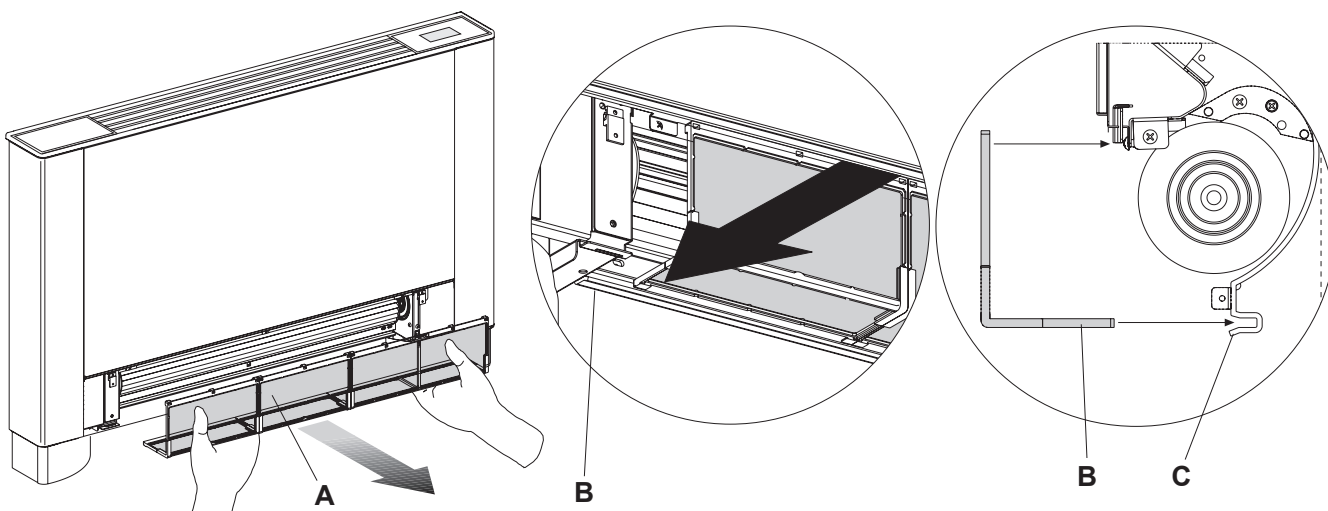

33

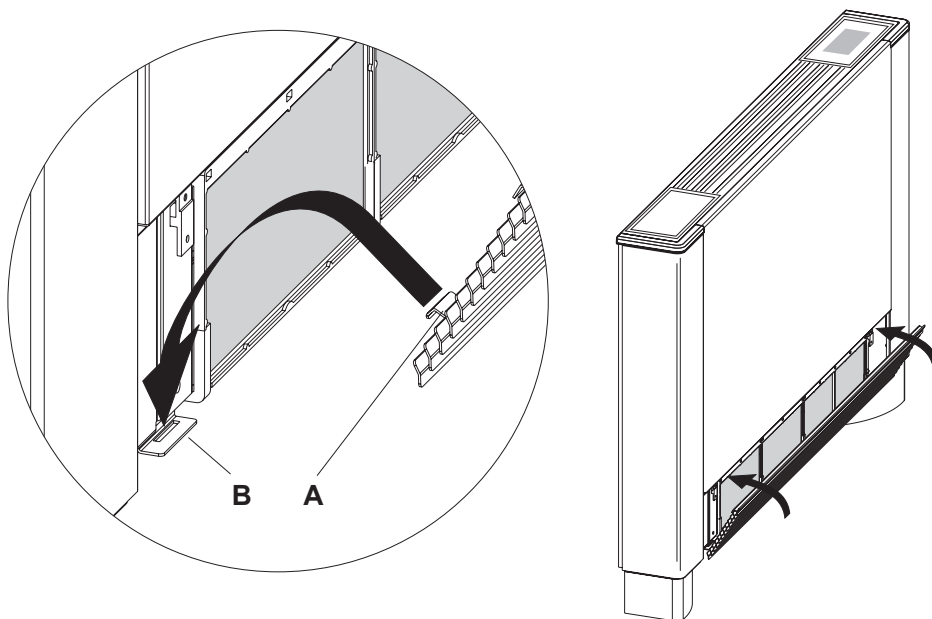



## ANOMALIES AND SOLUTIONS

In the event of water leaks or abnormal operation, disconnect the power supply immediately and close the water taps.

If one of the following anomalies is noted, contact an authorised service centre or professionally skilled personnel and do not intervene personally.

- Ventilation does not activate even if hot or cold water is present in the hydraulic circuit.
- The appliance leaks water in heating mode.

- The appliance leaks water only in cooling mode.
- The appliance emits excessive noise.
- Dew forms on the front panel.

### TABLE OF ANOMALIES AND SOLUTIONS

Works must be carried out by a skilled installer or a specialised service centre.

Effect	Cause	Solution
Ventilation activation is delayed with respect to the new temperature or operating settings.	The circuit valve requires a certain amount of time for it to open and therefore for the hot or cold water in the appliance to circulate.	Wait 2 or 3 minutes for the circuit valve to open.
The appliance does not activate ventilation.	No hot or cold water in the system.	Check that the water boiler or chiller is running.
Ventilation does not activate even if hot or cold water is present in the hydraulic circuit.	The hydraulic valve remains closed	Remove the valve body and check whether the water circulation is restored. Check the operating state of the valve by feeding it separately at 220 V. If it is activated, the problem may be in the electronic control.
	The ventilation motor is blocked or burned.	Check the motor windings and the free rotation of the fan.
	The microswitch that stops the ventilation when the filter grid is opened, does not close properly.	Check that the contact of the microswitch is activated when the grid closes.
	The electrical connections are incorrect.	Check the electrical connections.
The appliance leaks water in heating mode.	Leaks in the hydraulic connection of the system.	Check the leak and tighten the connections securely.
	Leaks in the valve assembly.	Check the condition of the gaskets.
Dew forms on the front panel.	Disconnected thermal insulators.	Check the correct positioning of the thermo-acoustic insulators with particular attention to the front one above the finned coil.
There are a few drops of water on the air outlet grid.	Condensation may occur in situations of high environmental relative humidity (>60%), especially at minimum ventilation speeds.	As the relative humidity tends to drop, the phenomenon disappears. In any case, any drops of water falling inside the appliance do not indicate a malfunction.
The appliance leaks water only in cooling mode.	The condensate pan is clogged.	Slowly pour a bottle of water into the lower part of the coil to check the drainage; if necessary, clean the pan and/or improve the gradient of the drain pipe.
	The condensate drain does not have the necessary gradient for correct drainage.	
	The connection pipes and the valve assembly are not insulated properly.	Check the insulation of the pipes.
The appliance emits excessive noise.	The fan touches the structure.	Check that the filters are dirty and if necessary, clean them
	The fan is unbalanced.	The unbalance determines excessive vibrations of the machine: replace the fan.
	Check that the filters are dirty and if necessary, clean them	Clean the filters

## HYDRAULIC KIT

### FITTING COMPONENTS

#### LIST OF HYDRAULIC ACCESSORIES

- 3-way valve assembly with diverter valve thermoelectric head kit for ETM, ETI

#### TYPES OF HYDRAULIC CONNECTIONS

N.B. In order not to penalise the system performance, the water input and output are those indicated in the various figures.

**ATTENTION: IN CASE OF MODELS WITH CONNECTIONS TO THE RIGHT, IF YOU HAVE NOT ORDERED THE DEVICE CONFIGURED ACCORDINGLY, YOU MUST INVERT THE POSITION OF THE COIL AND WIRING AS DESCRIBED IN THE PARAGRAPH ROTATING THE CONNECTIONS, IN THE INSTRUCTIONS FOR INSTALLATION, FOUND IN THE PACKAGING OF THE FAN COIL UNIT.**

**For quick and correct assembly of the components, follow the sequences shown in the various paragraphs.**

#### PIPING DIAMETER

The minimum internal diameter that is to be complied with for the hydraulic connection pipes varies, according to the model:

ETM-ETI 220	ø12 mm
ETM-ETI 240	ø14 mm
ETM-ETI 260	ø16 mm
ETM-ETI 280	ø18 mm
ETM-ETI 2100	ø20 mm

#### OPENING THE SIDES

- On the left side, lift the lid that covers the screw, loosen the screw that secures the left panel, move it slightly to the left and lift it.
- On the opposite side, lift the lid that covers the screw and unscrew it.
- Move the side panel slightly to the right and lift it.

A	lid
B	fixing screws
C	left panel
D	right panel

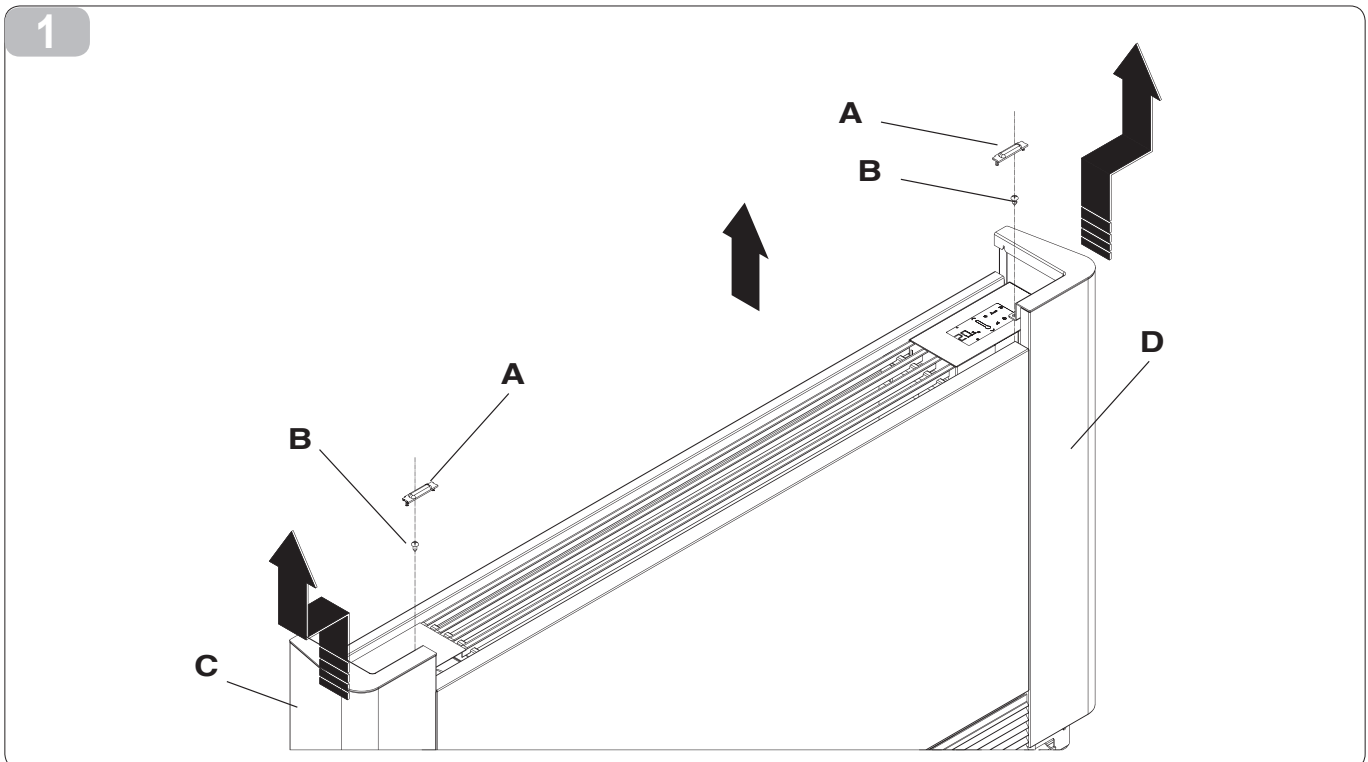

**ADJUSTING THE RETAINER**

The retainers provided with the hydraulic kits allow an adjustment that can balance the pressure drops of the system. The following procedure must be followed for the circuit to be balanced and adjusted correctly:

- 1 Use a screwdriver to unscrew and extract the slotted grub screw found inside the hexagonal slot
- 2 Close the adjustment screw with a 5 mm Allen key (fig. 4 ref. A)
- 3 Fully screw the slotted grub screw. Then mark the reference adjustment point with an "x" (fig. 4 ref. B).
- 4 Align the screwdriver on the "x". Then open with a number of rotations (fig. 4 ref. C) according to the diagram  $\Delta p-Q$  shown on the graphics page.

**ATTENTION: the number of revolutions refers to the micro-metric grub screw!**

Then fully open the screw (fig. 4 ref. D). The pre-adjustment has now been set and will not change if repeatedly opened and closed with the Allen key.

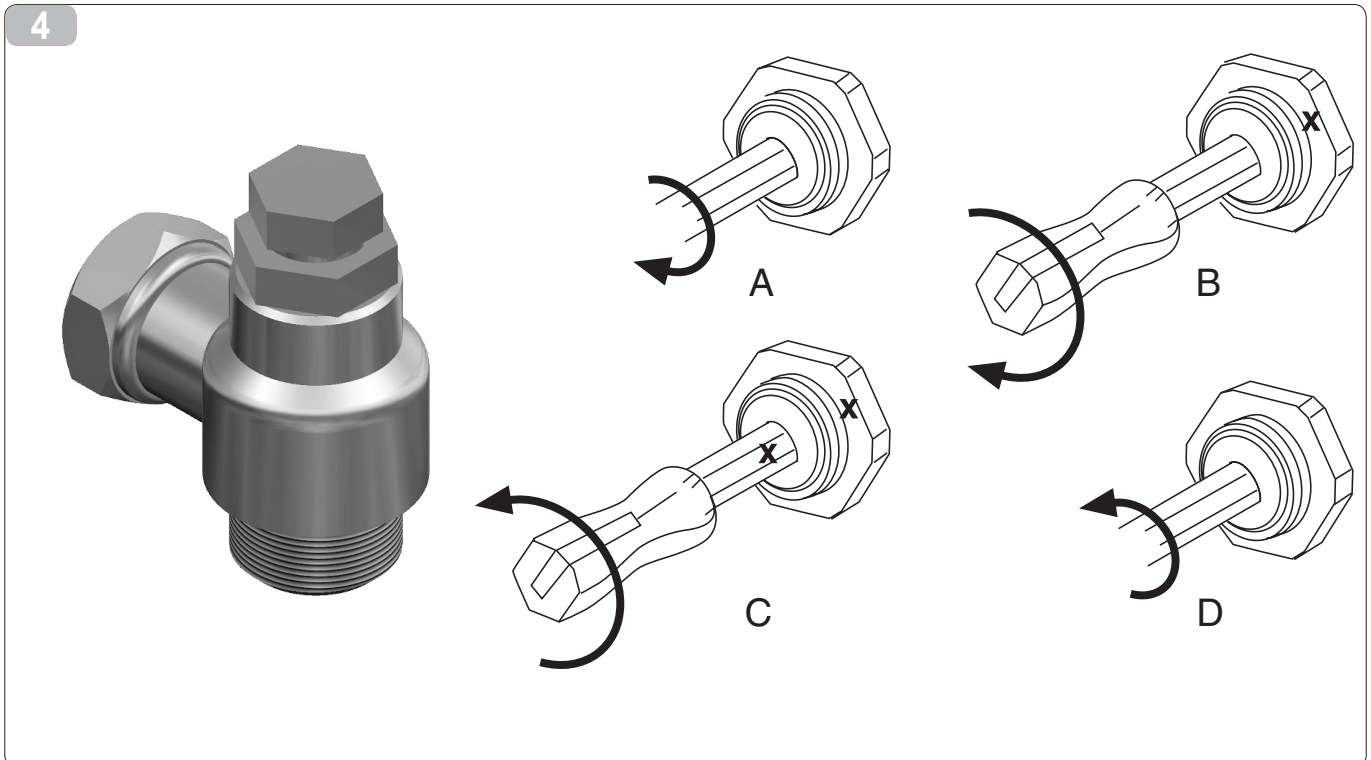

**3-WAY VALVE WITH DIVERTER VALVE THERMOELECTRIC HEAD KIT**

It consists of a 3-way diverter valve with a thermoelectric head and a retainer fitted with micrometric adjustment that can balance the pressure drops of the system (fig. 9).

Inside the kit there is the insulation material to be fitted on the valve and on the retainer.

**CONNECTIONS**

The designer is responsible for choosing and sizing the hydraulic lines, and must proceed according to technical standards and current legislation.

To make the connections:

- position the hydraulic lines (fig. 9 ref. A)
- tighten the connections using the "dual key" method (fig. 9 ref. B)
- check for leaks

- cover the connections with insulating material (fig. 9 ref. C).

The hydraulic lines and joints must be thermally insulated.

Avoid partial pipe insulation.

Avoid tightening too much so as not to damage the insulation.

For the threaded connections to be water tight use hemp and green paste; Teflon tape is recommended in the presence of antifreeze liquid in the hydraulic circuit.

9

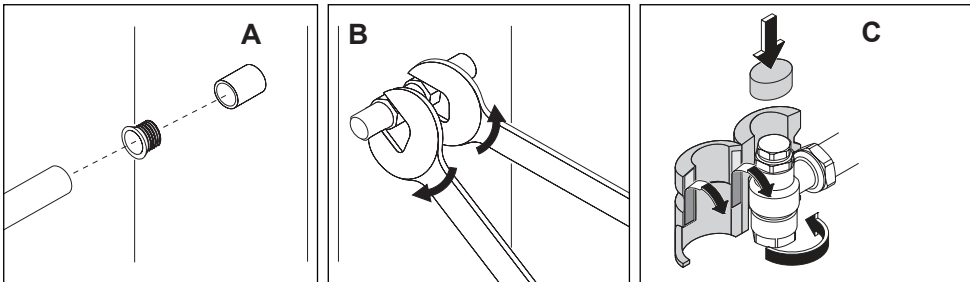

**ETM, ETI VERSION WITH 3-WAY DIVERTER VALVE**  
ETM, ETI versions

20

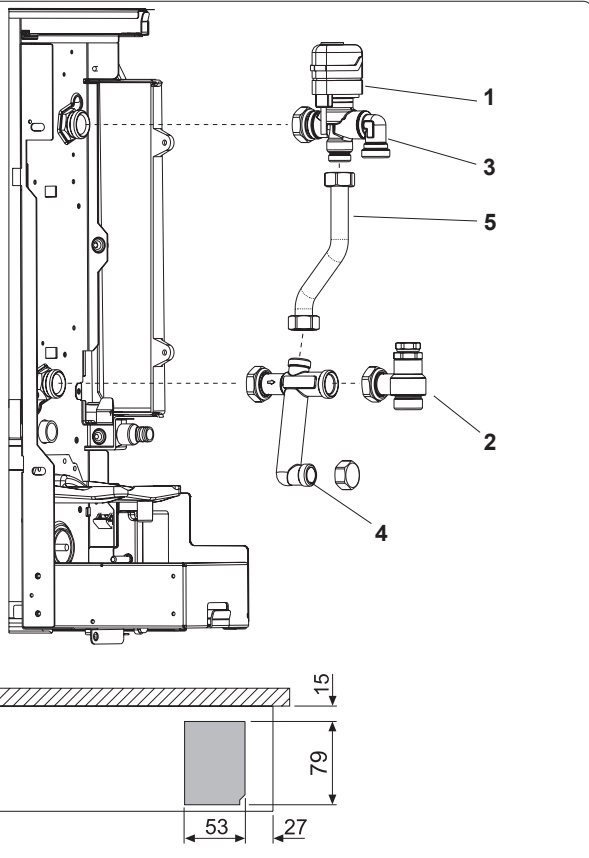

**FITTING THE THERMOSTATIC HEAD**

Screw the head tightly to the valve body.

- ⚠ Do not use mechanical tools to install the head, but only your hands!

The thermostatic head is supplied with a red tab that keeps it open so as to facilitate installation, filling and bleeding the system, even in the event of a power failure.

- ⚠ Remove the tab when starting up the system so as to prevent the valve from remaining open at all times

- A = Tab
- B = Valve Body
- C = Head

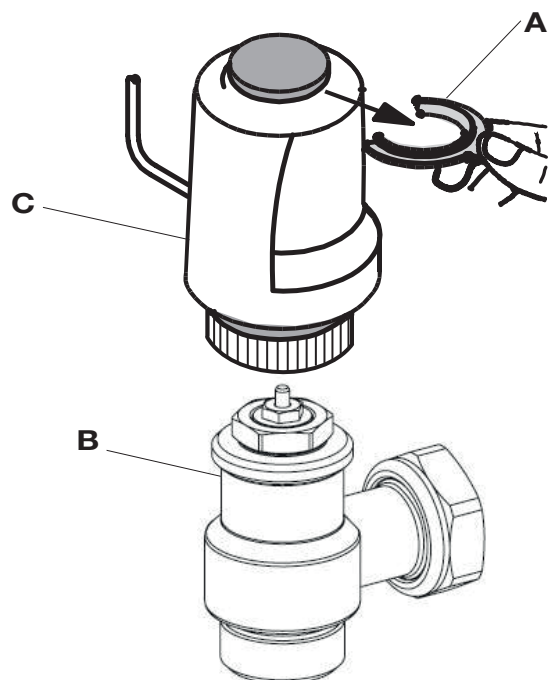

**Kit composition:**

- 1 thermoelectric head (1)
- 2 retainer
- 3 3-way valve (1)
- 4 output fitting
- 5 flexible pipe 1/2" 230 (1)
- 6 stub 3/4" EK (1 optional)

- floor-mounted connections version (fig. 20)
- wall-mounted connection version (fig. 21) (with spacer stub 3/4")
- Apply the insulating material provided.

⚡ Once the hydraulic components have been assembled, connect the thermoelectric head connectors to the wiring connectors found on the machine.

- Remove the side
- Assemble the components as shown in the figure:



## ETM-mallin sähkökytkennät

### Assembly and connections of the electrical box panel THIN-4-V

The control on board the machine with speed selector and ON/OFF button, room thermostat adjustable from 5 to 40°C, winter and summer selector and minimum winter temperature function (30°C) and maximum summer temperature (20°C), is suitable for installation on the machine and has a 230 V - 1 A output to control a solenoid valve.

### Assembly

Insert the control panel in its seat in the upper part of the appliance and secure it with the two screws provided (ref. A).

To install the board:

- secure the earth cable (ref. M) to the appliance structure using the screw provided (the minimum force that must be exerted for tightening must be about 2N);
- connect the motor quick connector (MOTOR) to that on the board (ref. I) \*.

NOTE: if the board is not installed in the factory, the fan motor must be rotated 180° according to the length of the standard fan coil cable.

- in the 2 terminals of the GRID terminal (ref. L) there is a bridge that guarantees the operation of the ETI versions without a microswitch.

For the other versions, remove the bridge and connect the two terminals coming from the safety grid microswitch.

NOTE: if the two brown terminals on the appliance are short, replace them with those in the kit's packaging.

connect the H2 water probe connector (ref. F) on the appliance; the water temperature probe controls the temperature inside the coil and determines fan start-up according to preset parameters (minimum winter and maximum summer functions). Check that it is inserted correctly in the pit on the coil.

make the electrical connections, and set the wiring in order;

refit the aesthetic side panel of the appliance;

tighten the upper screw on the control panel;

place the screw cover in the specific housing on the control panel;

\* For versions with hydraulic connections on the right, refer to the relevant paragraph.

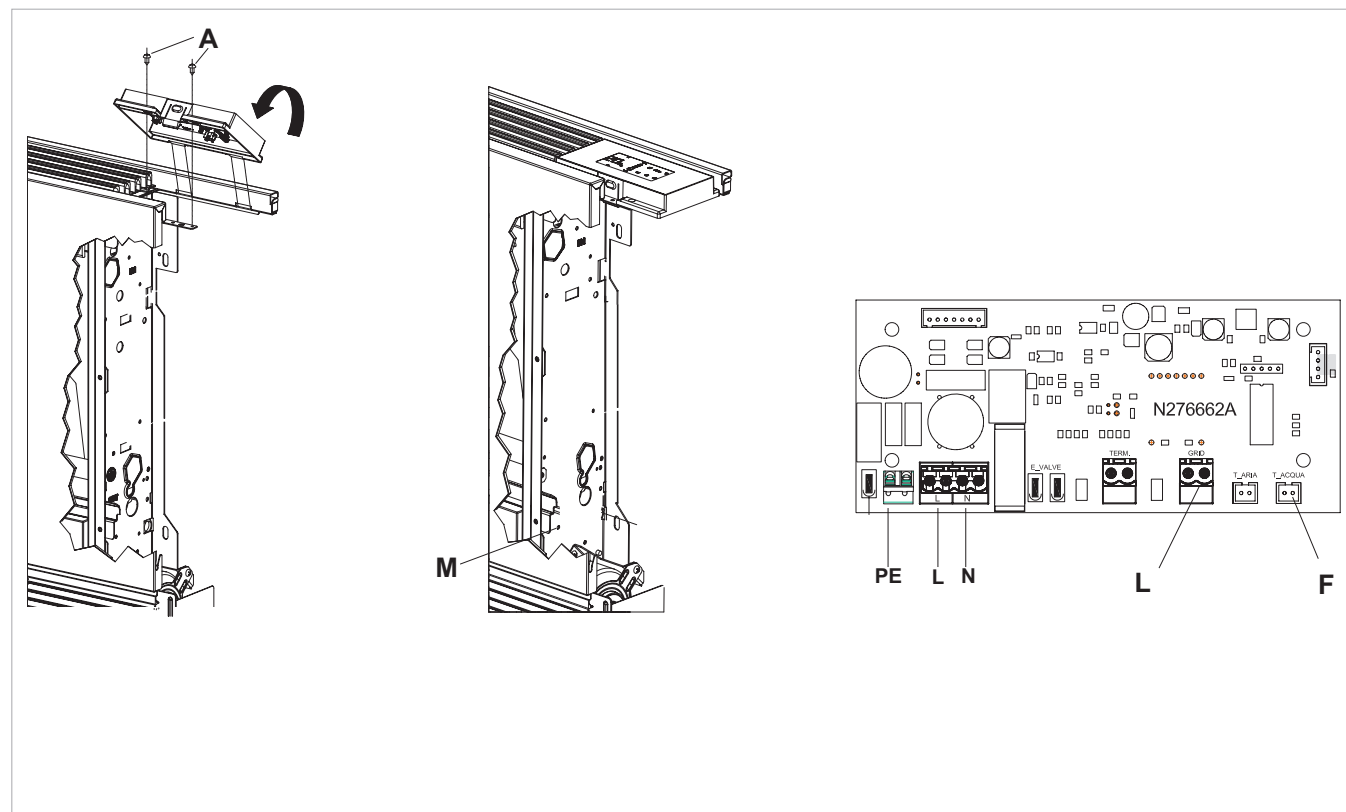

## Assembling the air temperature probe

To position the temperature probe (ref. A):

- pass the probe through the hole of the edge (ref. B)

- insert the probe in the lower hole (ref. C)

- secure the probe in the relevant coupling (ref. D).

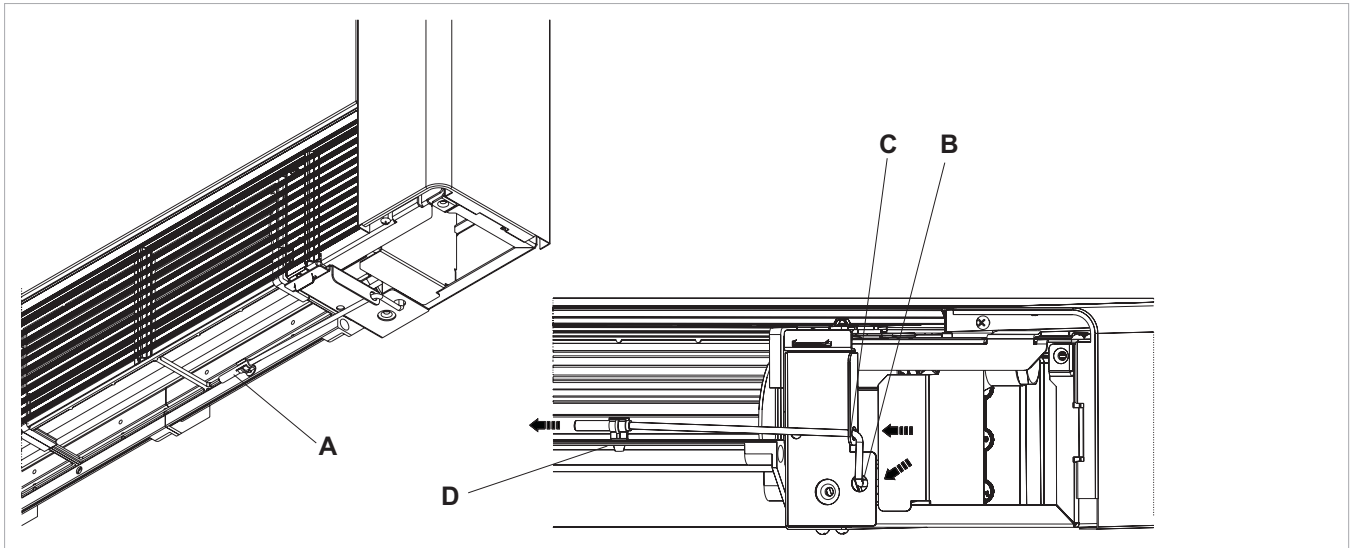

## Electrical box connections THIN-4-V

H2	water temperature probe 10 kΩ
M1	DC inverter fan motor
S1	grid safety microswitch
Y1	water solenoid valve (230V / 50Hz 1A voltage output)
L-N	230V / 50Hz power supply connection

### Electrical boxconnections THIN-4-V

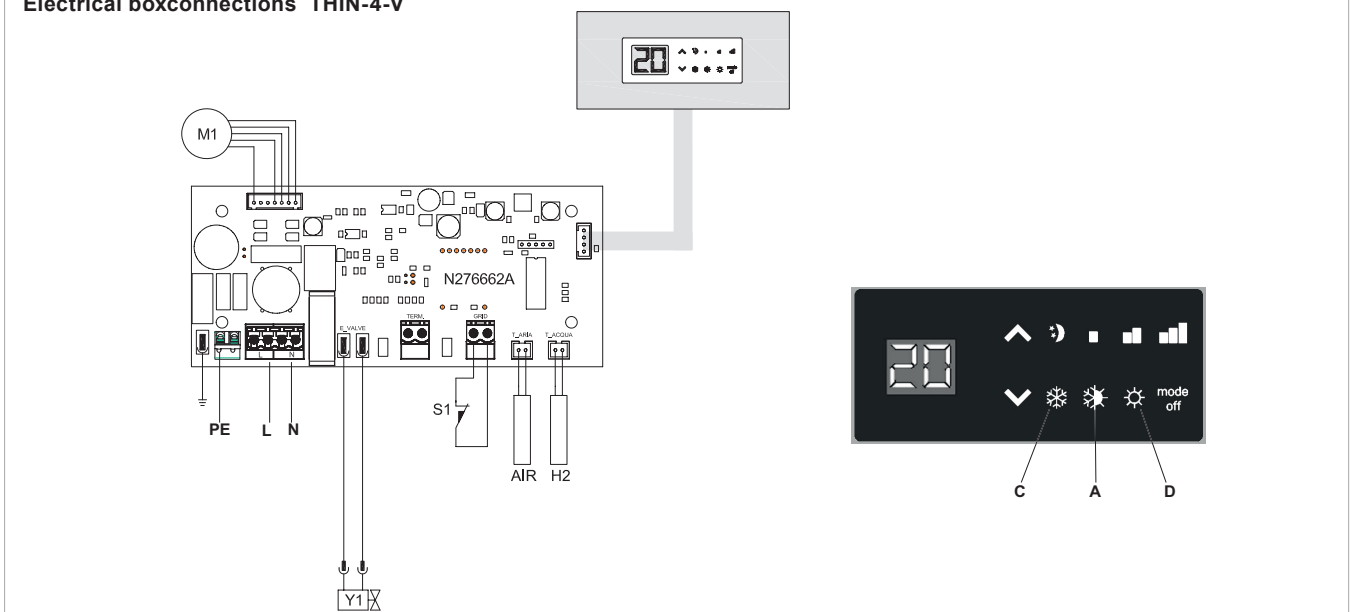

## Water probe management of the electrical box THIN-4-V

Start-up occurs under normal conditions if the board detects the water temperature detection probe, found on the appliance, positioned in the specific coil pit. If the probe is not connected, the absence is signalled by the red and blue LEDs flashing simultaneously, and the operation being blocked.

The summer/winter button must be pressed for 5 seconds (ref A) to confirm the probe-free operation.

This condition will be saved by the board for all subsequent start-ups.

In any case, normal operation with temperature thresholds is restored when the probe is connected.

If the machine runs with the probe connected and the water temperature is not suitable for active operation (above 20°C in cooling and below 30°C in heating), the ventilation will be stopped and the anomaly will be indicated by the corresponding LED of the selected function flashing (cooling blue C or heating red D).

## ETI-mallin sähkökytkennät

### Assembly and fan control connections for THIN-TBK remote adjustment

Mounted on the machine, it allows the motor to be managed with fixed speeds; it can be combined with thermostat controls and all the controls available on the market.

It has a 230 V output to drive the summer and winter solenoid valve.

### Assembly

Insert the blind panel in its seat in the upper part of the appliance and secure it with the two screws provided (ref. A).

To install the connection box:

- open the box (ref. B);
  - engage the lower tooth in the relevant slot (ref. C) on the side of the appliance;
  - engage the upper part of the box at the side (ref. D);
  - secure it with the two screws provided (ref. E);
  - secure the earth cable to the appliance structure (ref. M) using the screw provided (the minimum force that must be exerted for tightening must be about 2N);
  - in the 2 terminals of the SW GRL terminal (ref. L) there is a bridge that guarantees the operation of the ETI versions without a microswitch.
- For the other versions, remove the bridge and connect the two terminals coming from the safety grid microswitch\*;
  - connect the motor quick connector (MOTOR) to that on the board (ref. I);
  - make the electrical connections, set the wiring in order and secure the cables using the 3 jumpers provided (ref. G);
  - close the box by securing the 4 screws (ref. H);
  - refit the aesthetic side panel of the appliance;
  - tighten the upper screw on the blind panel;
  - place the screw cover in the specific housing on the blind panel;

\* For versions with hydraulic connections on the right, refer to the relevant paragraph

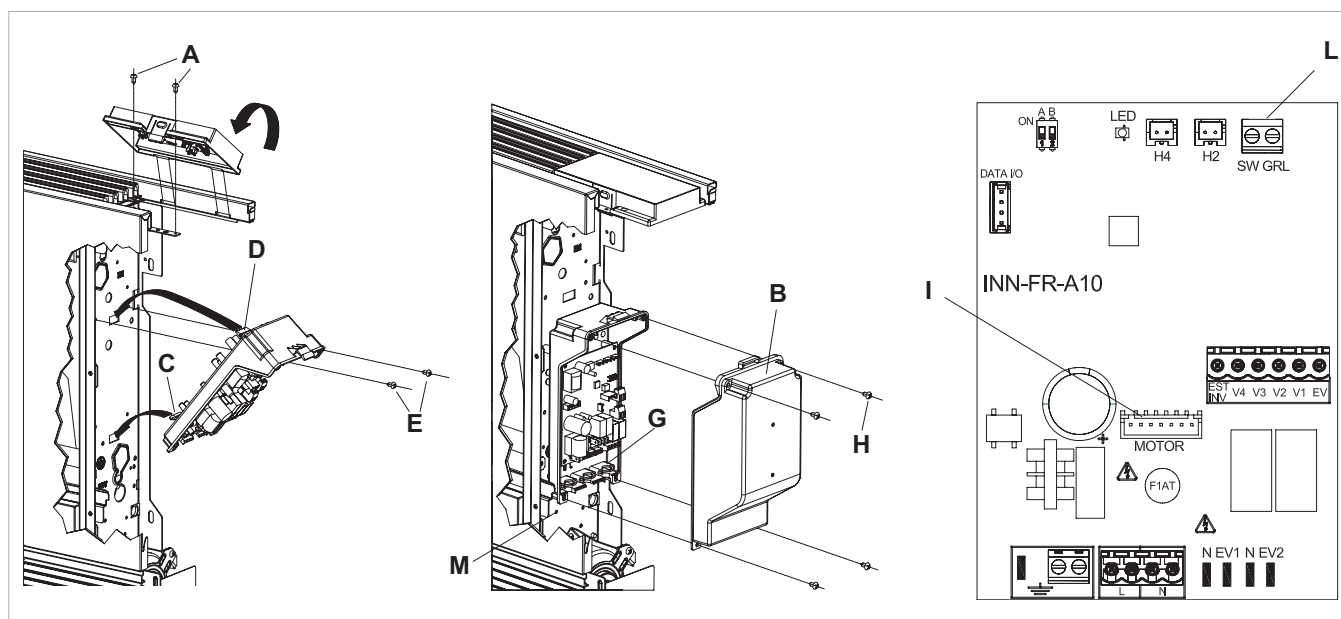

### THIN-TBK connections diagram with 3-speed thermostats

Make the electrical connections to a thermostat that is suitable for the purpose, according to the diagram in the figure

L-N	electrical supply 230V-50Hz
EV	solenoid valve enable input
V1	fan maximum speed
V2	fan medium speed
V3	fan minimum speed
V4	super-silent speed
E	heating, cooling selection input – see paragraph Water probe management
Y1	water solenoid valve (voltage output at 230V / 50Hz / 1A)

M1	inverter DC fan motor
S1	grid safety microswitch
TA	3-speed room thermostat (to be purchased, installed and connected by the installer)
CV	thermostat enable
SV	speed selector
H2*	water temperature probe (10 kΩ)
*	placed in the coil on the machine. See paragraph Water probe management

## LED signals

The LED (ref. A) is off if the CV input is not closed (stand-by condition).

It is switched on when the CV contact closes and indicates normal operation.

- Flashes frequently if the S1 grid safety microswitch is activated due to the filter cleaning operation.
- Makes a single flash + pause for fan stop alarm due to inadequate water (with H2 water probe connected).

- 2 flashes + pause due to motor alarm (for example, jam due to foreign bodies or fault in the rotation sensor).
- 3 flashes + pause due to disconnected or faulty water probe alarm.

## Water probe management with three-speed thermostat

If the THIN-TBK board is used with electromechanical thermostats, or other commercial controls, fitted with a water probe, the H2 probe on the machine must not be connected and the fan is remote controlled. If, on the contrary, the command does not include the management of the water probe, this function can be performed by the board, by connecting the 10 kΩ probe found in the coil, to the H2 connector of the board (ref. B).

In this case, the board performs the minimum water temperature for heating operation and maximum water temperature in cooling functions and therefore, if the water temperature is not suitable for active operation (above 20°C in cooling, below 30°C in heating), the ventilation is stopped and the anomaly is signalled by the single flash + pause of the LED (ref. A).

The heating/cooling discriminant is implemented via the SUM-WIN

input (ref. C) of the board: leaving it open, the board goes into heating mode; closing it, it goes into cooling mode.

If after connecting the probe, it is disconnected or measures inconsistent values (e.g. installation of probe 2 kΩ instead of the correct one of 10 kΩ), the anomaly is signalled with 3 flashes + pause of the LED (ref. A) and blocked operation.

To confirm operation without the probe, disconnect and re-energise the board.

This condition will be saved by the board for all subsequent start-ups. In any case, normal operation with temperature thresholds is restored when the probe is connected.

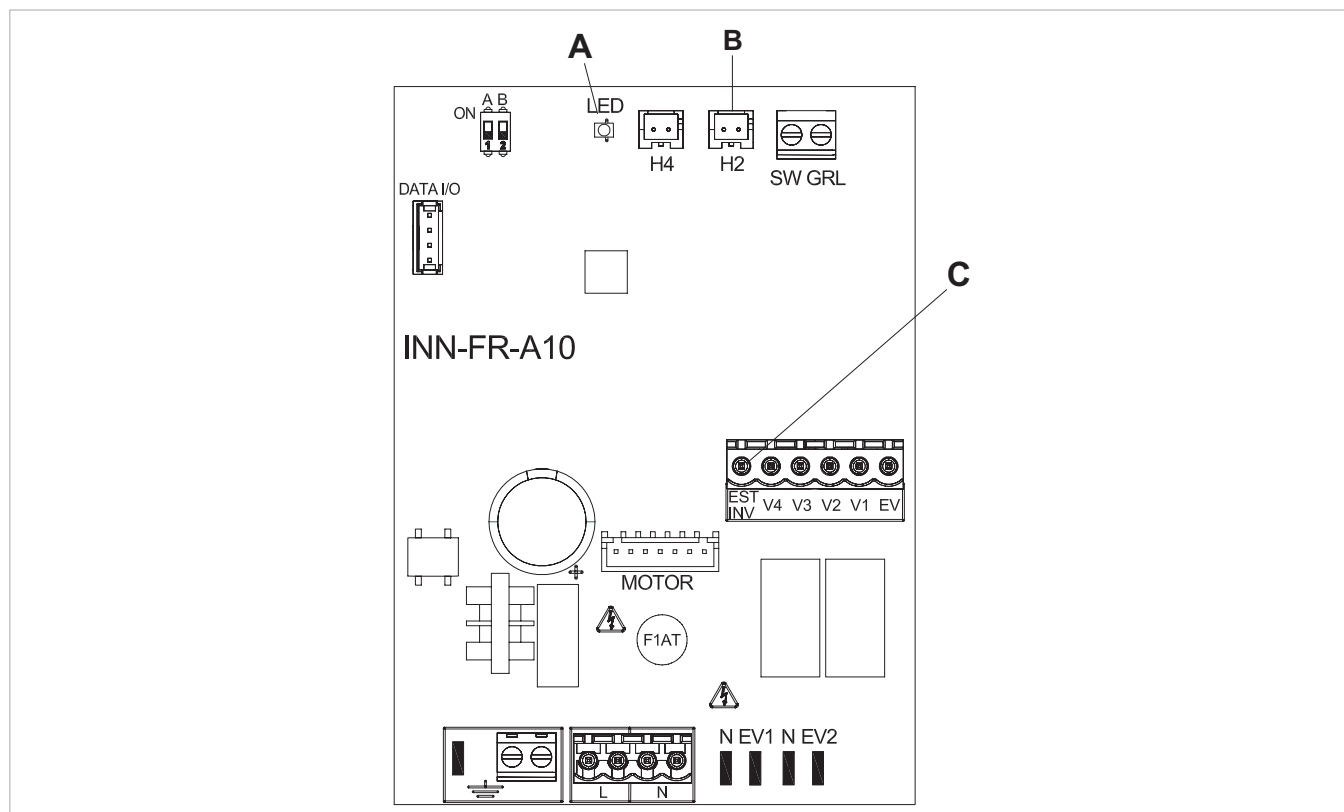

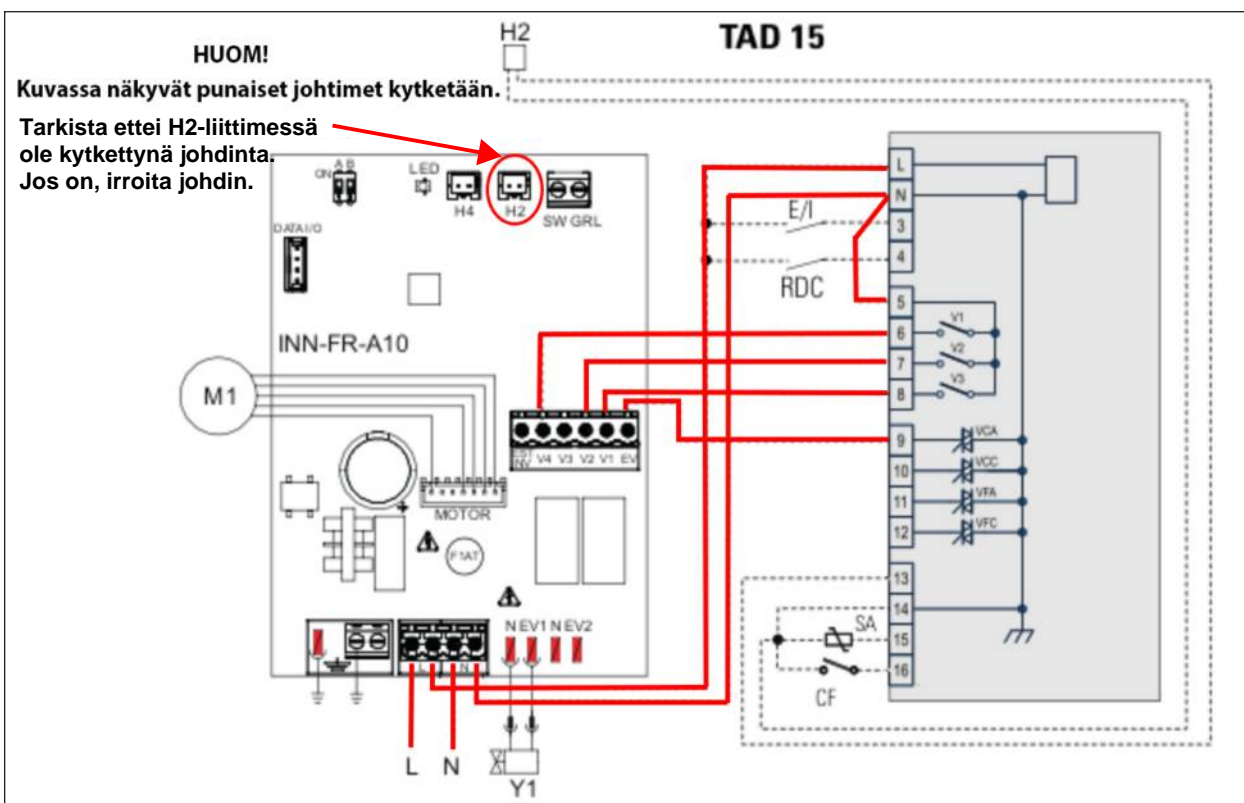
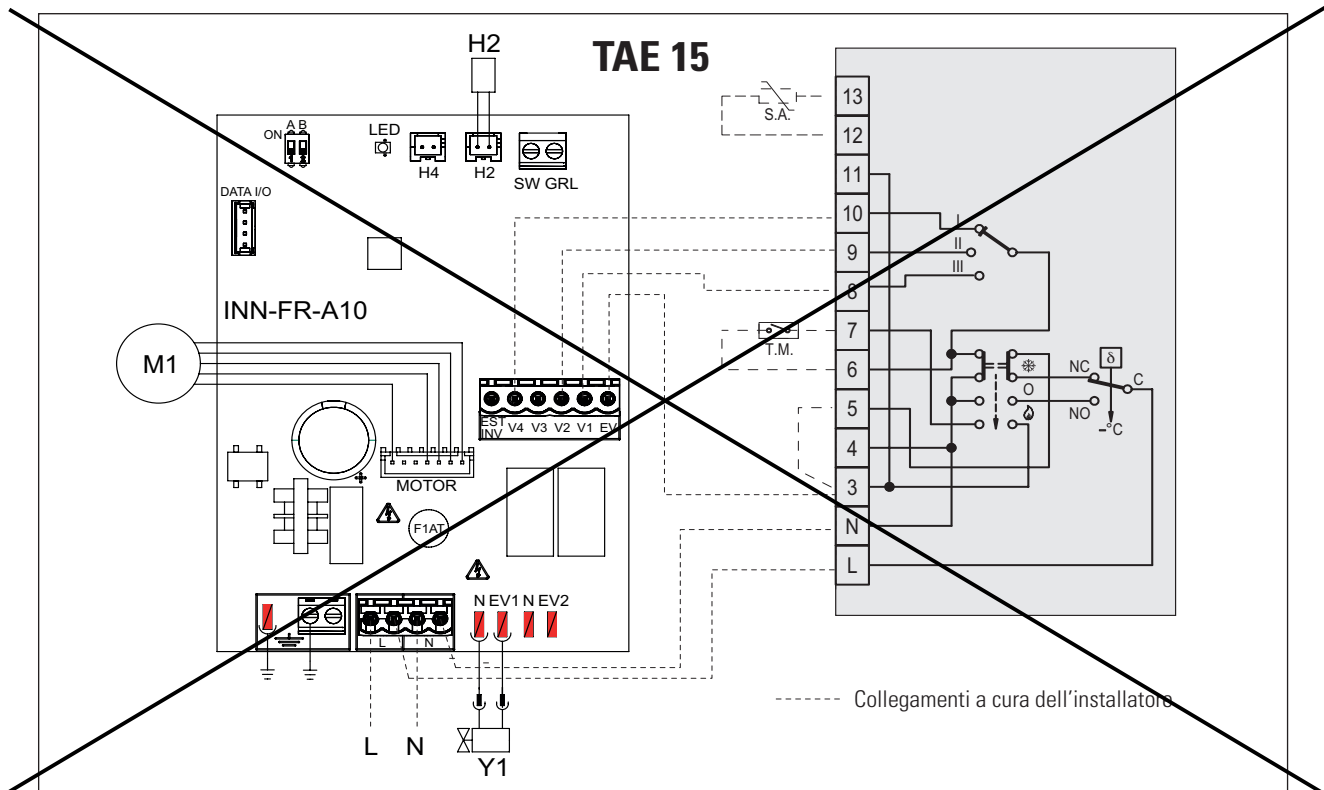

<b>L-N</b>	Power supply 230v-50hz
<b>EV</b>	Board ON OFF
<b>V1</b>	Fan maximum speed
<b>V2</b>	Fan medium speed
<b>V3</b>	Fan minimum speed
<b>V4</b>	Super-silent speed
<b>Y1</b>	Water solenoid valve (voltage output at 230V / 50Hz / 1A)
<b>M1</b>	Inverter DC fan motor
<b>H2*</b>	Water temperature probe (10 k) ntc
<b>*</b>	Placed in the coil on the machine. See paragraph water probe management
<b>SA</b>	Remote room probe

<b>TM</b>	Minimum water temperature thermostat
<b>CF</b>	Remote input to activate the "window contact" function
<b>E/I</b>	Remote input to activate the "Centralised summer/winter" function
<b>RDC</b>	Remote input to activate the "economy" function

## ETM-mallin ohjain

### THIN-4-V electric box control panel

The control makes the room temperature adjustment fully autonomous by setting the adjustable setpoint from 5 to 40°C, one of the 4 speeds and the summer/winter selection.

Being connected to the water temperature detection probe inside the coil, it performs the minimum winter temperature (30°C) and maximum summer temperature (20°C) function.

The control panel is fitted with a memory so all settings will not be lost if shut-down or in the event of a power failure.

⚠ The commands cannot be installed on the ETI version

⚠ After a period of 20 seconds from the last action, the brightness of the panel is specifically reduced to increase the comfort during the night-time and the display shows the room temperature. Maximum brightness is reset when any key is pressed.

A	Display
B	Keys and LEDs

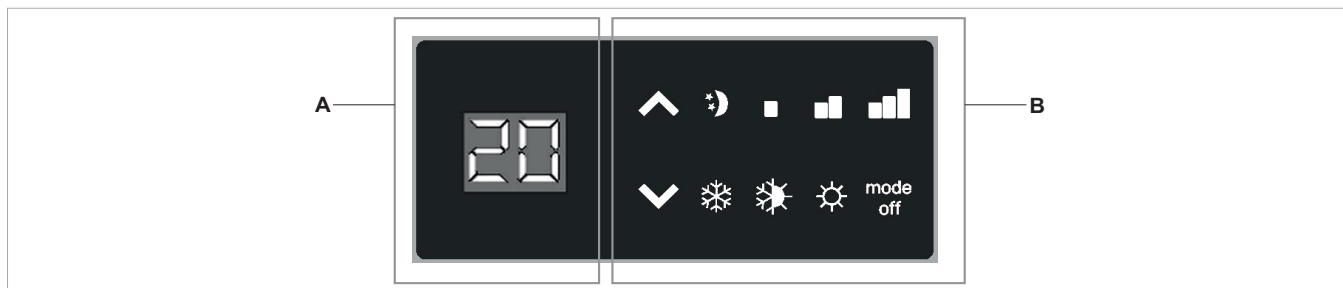

### LED indications

The 6 LEDs display the operating statuses:

	Green minimum speed symbol
	Green medium speed symbol
	Green maximum speed symbol

	Green Supersilent mode symbol
	Red heating symbol
	Blue cooling symbol

### Key function

The various functions are set via 4 keys:

	Temp + allows you to increase the set temperature
	Temp - allows you to decrease the set temperature

	Heating/Cooling: allows the operating mode to be switched between heating and cooling (2 seconds)
<b>mode off</b>	Allows you to activate the appliance, select one of the 4 speeds or set it to stand-by (2 seconds).

### General switch-on

For the fan coil unit to be managed via the control panel, this must be connected to the mains.

If a master switch has been fitted on the power supply line, this must be connected.



- Switch the system on by connecting the master switch

## LED indications

Activate the appliance by

Key	Operation	Display
<b>mode off</b>	Press the mode/off key	Off → On
<b>mode off</b>	Select one of the 4 operating modes by pressing the relative mode/off key. In heating mode, the symbols remain on with a setpoint higher than the room temperature; off with a lower setpoint. In cooling mode, the symbols are on with a setpoint lower than the room temperature; off with a higher setpoint.	

## Heating / cooling operating mode setting



Key	Operation	Display
	Press and hold the Heating / Cooling key for about 2 seconds to switch the operating mode between heating and cooling, visible through the activation of the 2 active heating or cooling symbols.	

The flashing of one of the 2 symbols indicates that the water temperature (hot or cold) is not reached and causes the fan to stop until the temperature reaches a value that is suitable to fulfil the request.

## Stand By

Key	Operation	Display
<b>mode off</b>	Keep the mode/off key pressed for about 2 seconds. The absence of any luminous signal from the display identifies the “stand-by” status (no mode).	On → Off

## Temperature selection

Key	Operation	Display
	Use the two increase and decrease keys to set the desired temperature value displayed on the 2 digits of the display.	

The adjustment range is from 15 to 30°C, with a resolution of 1°C, but values outside the range of 5°C (Lo) and 40°C (Hi) are also allowed. Set these values only for short periods and then adjust the selection to an intermediate value. The command is very precise; bring it to the desired value and wait for the command to make the adjustment based on the actual room temperature detected.



## Speed adjustment

Key	Operation	Display
<b>mode off</b>	Every time the mode/off key is pressed, the fan speed changes between supersilent, minimum, medium and maximum. The activation of the function is signalled by the relative symbol on the display going on	

The supersilent speed will give rise to strong dehumidification in cooling mode and to a radiant only function in heating mode (with the fan off and the solenoid valve activated). Setting the maximum speed, the maximum power that can be delivered is immediately obtained in both heating and cooling.

Once the desired room temperature is reached, it is advisable to select one of the other 3 operating modes to obtain better thermal and acoustic comfort.

## Key lock

Key	Operation	Display
	Pressing the temperature increase and decrease keys simultaneously for 5 seconds activates the local locking of all the keys, and confirmation is implemented on bL being displayed. All adjustments are inhibited for the user and bL appears when any key is pressed. Repeating the sequence unlocks the keys.	<b>bL</b>
		

## Reducing brightness

After a period of 20 seconds from the last action, the brightness of the panel is specifically reduced to increase the comfort during the night-time and the display shows the room temperature.

Should this brightness be still annoying, the display can be turned off completely by pressing the Heating/Cooling button for 20 seconds until  appears on the display.

Restore the normal minimum brightness by pressing the Heating/Cooling button for 20 seconds until  appears on the display.





## Key lock

Key	Operation	Display
<b>mode off</b>	Keep the mode/off key pressed for about 2 seconds. The absence of any luminous signal from the display identifies the "stand-by" status (no mode).	On → Off

## Error signals

In case of seasonal or holiday shutdowns, proceed as follows:

- Deactivate the appliance.
- Set the master switch of the system to Off

Error	Led	Display
Faulty room temperature probe (AIR). Flashing of the 6 LEDs (automatic reset alarm).		<b>E1</b>
Fault in the water temperature detection probe (H2) found in the main coil. Flashing of the 2 LEDs (possible manual reset)*.		<b>E3</b>
Fan motor problem (for example, jam due to foreign bodies or fault in the rotation sensor). Simultaneous flashing of the 4 LEDs (automatically reset alarm).		<b>E2</b>
Water demand (hot or cold) not satisfied (above 20°C in cooling, below 30°C in heating). The LED of the selected function flashes and the fan is stopped until the water temperature reaches a value that is suitable to satisfy the request.		
Grid protection microswitch activation due to the grid being opened accidentally or filter cleaning operation		<b>Gr</b>

\* Start-up occurs under normal conditions if the board detects the water temperature detection probe, found on the appliance. If the probe is not connected, probe-free operation can be confirmed by pressing the Heating/Cooling button for 5 seconds.



Technical data						
Model		ETM / ETI	220	240	260	280
Total cooling capacity (1)		kW (max)	0.76	1.77	2.89	3.20
		kW (med)	0.61	1.36	2.16	2.52
		kW (min)	0.36	0.66	1.30	1.82
Sensitive cooling capacity (1)		kW (max)	0.68	1.33	2.09	1.78
		kW (med)	0.56	0.98	1.53	1.55
		kW (min)	0.31	0.39	0.99	1.22
Latent cooling capacity (1)		kW (max)	0.09	0.44	0.80	1.42
		kW (med)	0.06	0.38	0.64	0.97
		kW (min)	0.05	0.27	0.31	0.60
Water flow rate (1)		l/h (max)	131	304	497	551
		l/h (med)	105	234	372	434
		l/h (min)	62	114	224	313
Pressure drops (1)		kPa (max)	4.7	2.9	27.0	24.0
		kPa (med)	1.2	2.8	19.3	13.1
		kPa (min)	1.0	1.2	4.3	2.1
Heat capacity (2)		kW (max)	0.97	2.18	3.11	3.88
		kW (med)	0.73	1.63	2.33	3.05
		kW (min)	0.38	0.95	1.24	1.90
Water flow rate (2)		l/h (max)	168	374	535	668
		l/h (med)	125	280	401	525
		l/h (min)	65	164	212	327
Pressure drops (2)		kPa (max)	7.8	7.2	11.5	21.3
		kPa (med)	3.8	4.2	3.3	11.2
		kPa (min)	1.5	1.3	8.6	3.8
Air flow rate		m <sup>3</sup> /h (max)	146	294	438	567
		m <sup>3</sup> /h (med)	90	210	318	411
		m <sup>3</sup> /h (min)	49	118	180	247
Sound power level		dB(A) (max)	50	51	53	55
		dB(A) (med)	44	45	46	47
		dB(A) (min)	33	35	36	36
Total absorbed electrical power		kW (max)	0.011	0.019	0.020	0.029
		kW (med)	0.006	0.009	0.010	0.013
		kW (min)	0.003	0.005	0.004	0.005
Max power		W	12	21	22	32
Max current		A	0.11	0.18	0.19	0.28
Power supply		V/Ph/Hz	230/1/50			
Coil water content		l	0.47	0.80	1.13	1.46
Max operating pressure		bar	10			
Min-max water temperature		°C	4 - 70			
Water input/output connections (3)	Ø	inch	3/4" Eurocono			
Condensate drain connection	Ø	mm	14			
(1) Cooling: Room air temperature 27 °C d.b 19 °C w.b. - Input water temperature 7 °C - Dt water 5 °C						
(2) Heating: - Room air temperature 20 °C - Input water temperature 45 °C - Dt water 5 °C						
(3) Standard coil left connections						
* Information requirements for fan coil units in accordance with Regulation (EU) 2016/2281						

