

LINEAR MOTORIZED VALVES

# CONTROL VALVE PN16 SERIES VLE100

ESBE control valves series VLE122 and VLE132 are 2-way and 3-way external threaded valves for PN16, DN 15-50.



VLE122  
External thread PN16

VLE132  
External thread PN16

### MEDIA

These valves can handle the following types of media:

- Hot and cold water.
- Water containing phosphate or hydrazine additives.
- Water with antifreeze additives such as glycol.

If the valve is used for media at temperatures below 0°C (32°F), it should be equipped with a stem heater in order to prevent ice formation on the valve stem.

### ACCESSORIES DN 15 - 50

Connection sets with Internal Thread Fittings or Soldering Fittings are available as an option.

Art. No. \_\_\_\_\_ Adaptor kit, Siemens SQX  
26000700 \_\_\_\_\_

### CONTROL VALVE DESIGNED FOR

- Heating
- Comfort Cooling
- Floor heating
- Solar heating
- Ventilation
- District Heating
- District Cooling

### SUITABLE ACTUATORS

- Series ALB140
- Series ALFxx1
- Series ALFxx4

### TECHNICAL DATA

Type: \_\_\_\_\_ 2- and 3-way plug valve  
 Pressure class: \_\_\_\_\_ PN 16  
 Flow characteristic A-AB: \_\_\_\_\_ EQM  
 Flow characteristic B-AB: \_\_\_\_\_ Complementary  
 Stroke: \_\_\_\_\_ 20 mm  
 Rangeability Kv/Kv<sup>min</sup>: \_\_\_\_\_ see table  
 Leakrate A-AB, - DN15: \_\_\_\_\_ max. 0,02% of Kv 4  
 - DN 20-50: \_\_\_\_\_ max. 0,02% of Kvs  
 Leakrate B-AB, - DN15: \_\_\_\_\_ max. 0,05% of Kv 4  
 - DN 20-50: \_\_\_\_\_ max. 0,05% of Kvs  
 ΔP<sub>max</sub>: \_\_\_\_\_ see catalogue  
 Media temperature: \_\_\_\_\_ max. +150°C  
 \_\_\_\_\_ min. -20°C  
 Connection: \_\_\_\_\_ External pipe thread, ISO 228/1

Material  
 Body: \_\_\_\_\_ Bronze Rg5  
 Stem: \_\_\_\_\_ Stainless steel SS 2346  
 Plug: \_\_\_\_\_ Stainless steel SS 2346  
 Seat: \_\_\_\_\_ Stainless steel SS 2346  
 Blind plug: \_\_\_\_\_ Brass CW602N  
 Seat seal: \_\_\_\_\_ Metallic  
 Packing box seal: \_\_\_\_\_ PTFE/EPDM

CE PED 2014/68/EU, article 4.3 UK CA EAC

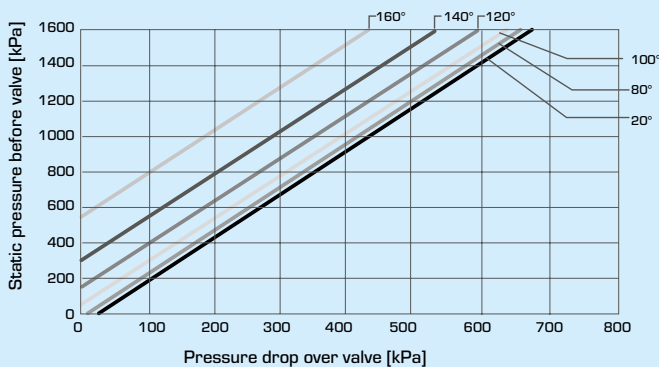

Pressure drop limit where cavitation might occur. Is dependent of valve inlet pressure and temperature of water.

### VALVE CHARACTERISTICS

2-way valves, DN15-50

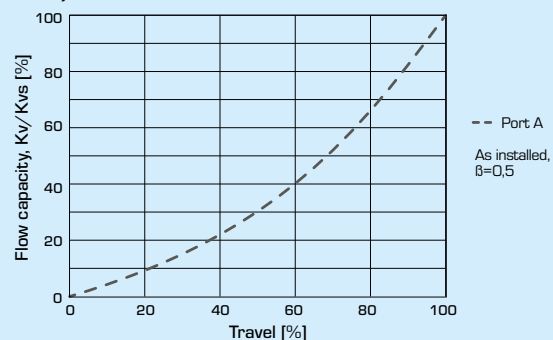

3-way valves, DN15-50

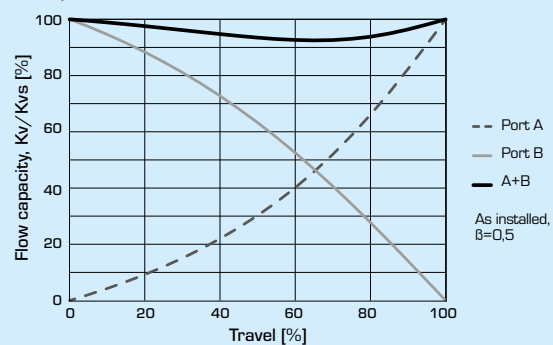

# CONTROL VALVE PN16

## SERIES VLE100

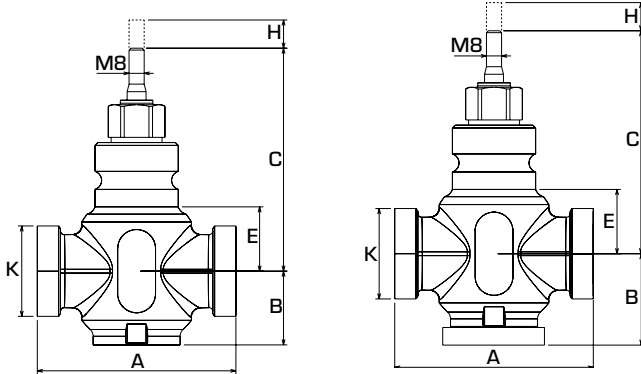

### 2-WAY CONTROL VALVE SERIES VLE122

Art. No.	Reference	DN	Kvs*	A	B	C	E	H	K	Rangeability Kv/Kv <sup>min</sup>	Weight [kg]
21250100	VLE122	15	0,25	100	36	110	24	20	G 1"	>50	1,0
21250200			0,4								
21250300			0,63								
21250400			1								
21250500			1,6								
21250600			2,5								
21250700	4										
21250800	VLE122	20	6,3	100	38	116	30	20	G 1 1/4"	>100	1,2
21250900	VLE122	25	10	105	39	120	34	20	G 1 1/2"	>100	1,4
21251000	VLE122	32	16	105	39	121	35	20	G 2"	>100	1,8
21251100	VLE122	40	25	130	48	128	42	20	G 2 1/4"	>100	2,6
21251200	VLE122	50	38	150	58	139	53	20	G 2 3/4"	>100	4,3

### 3-WAY CONTROL VALVE SERIES VLE132

Art. No.	Reference	DN	Kvs*	A	B	C	E	H	K	Rangeability Kv/Kv <sup>min</sup>	Weight [kg]
21251300	VLE132	15	1,6	100	50	110	24	20	G 1"	>50	1,1
21251400			2,5								
21251500			4								
21251600	VLE132	20	6,3	100	50	116	30	20	G 1 1/4"	>100	1,3
21251700	VLE132	25	10	105	52	120	34	20	G 1 1/2"	>100	1,6
21251800	VLE132	32	16	105	52	121	35	20	G 2"	>100	2,0
21251900	VLE132	40	25	130	65	128	42	20	G 2 1/4"	>100	2,9
21252000	VLE132	50	38	150	75	139	53	20	G 2 3/4"	>100	4,6

\* Kvs-value in m<sup>3</sup>/h at a pressure drop of 1 bar.

# CONTROL VALVE PN16

## SERIES VLE100

### FLOW CHART

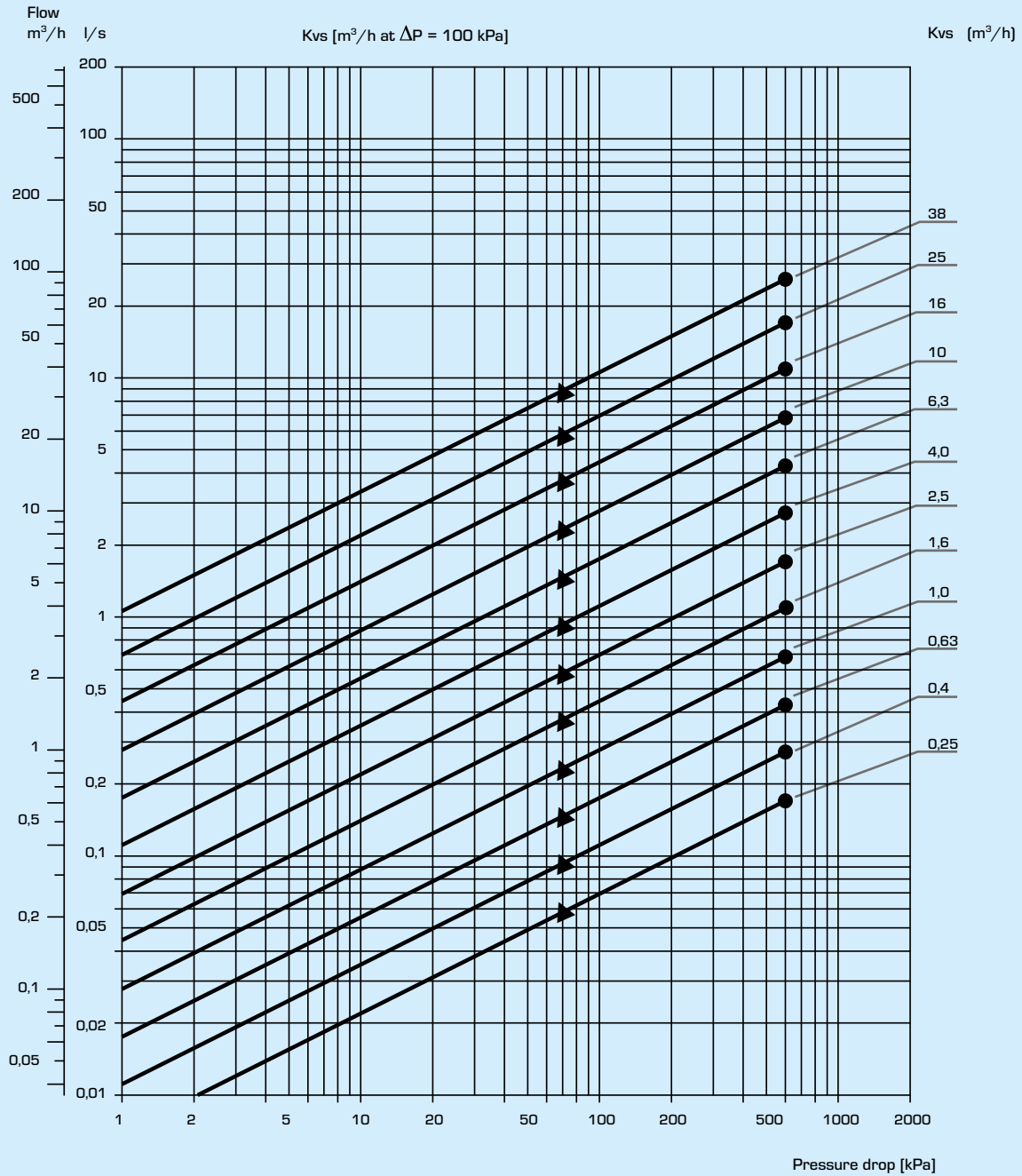

*To be considered: As both the viscosity and the thermal conduction are affected when glycol is added to the system water, this fact has to be considered when dimensioning the valve. A good rule is to choose one size higher Kv-value when 30 - 50% glycol is added. A lower concentration of glycol may be disregarded. N.B.! Maximum 50% glycol for freezing protection and oxygen absorbing compounds are allowed as additives.*

# CONTROL VALVE PN16 SERIES VLE100

## INSTALLATION

The valve should be mounted with flow direction in accordance with the valve marking.

If possible, the valve should be installed in the return pipe, in order to avoid exposing the actuator to high temperatures.

The valve must not be installed with the actuator mounted below the valve.

### Mounting positions:

A = Allowed mounting position with fluid temperature between -20°C to +120°C.

B = Allowed mounting position with fluid temperature between 0°C to +150°C.

C = Not allowed mounting position.

To ensure that suspended solids will not become jammed between the valve plug and seat, a filter should be installed upstream of the valve, and the pipe system should be flushed before the valve is installed.

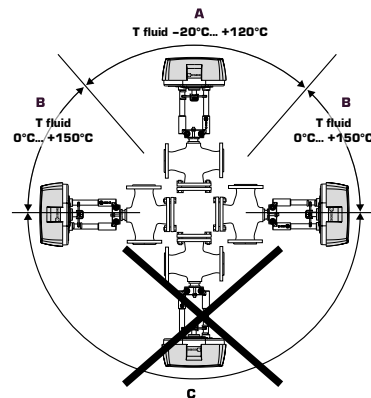

## VALVE AUTHORITY [ $\beta$ ]

$\Delta p_v$  - pressure losses over the valve [bar]

$\Delta p_{sys}$  - pressure losses over the system with variable flow [bar]

$\Delta p_{inst}$  - pressure losses over the installation [bar]

Recommendation : Valve authority [ $\beta$ ] shall be between 0,3 to 0,7

### a) 2-way valve

$$\beta = \frac{\Delta p_v}{\Delta p_v + \Delta p_{inst}}$$

### b) 3-way valve

$$\beta = \frac{\Delta p_v}{\Delta p_v + \Delta p_{sys}}$$

## INSTALLATION EXAMPLES

### 2-WAY CONTROL VALVES

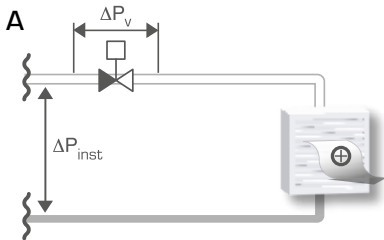

Installation without local circulating pump

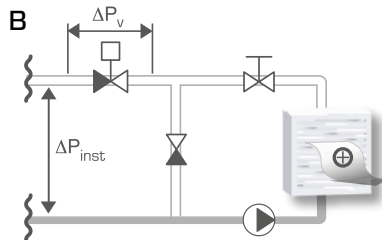

Installation with local circulating pump

### 3-WAY CONTROL VALVES

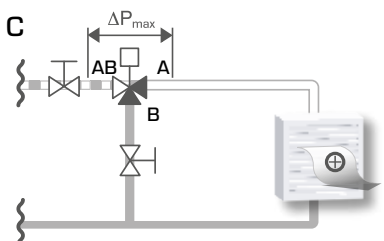

Circuit without local circulation pump

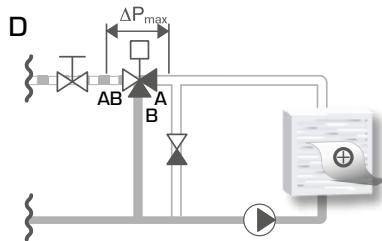

Circuit with local circulation pump

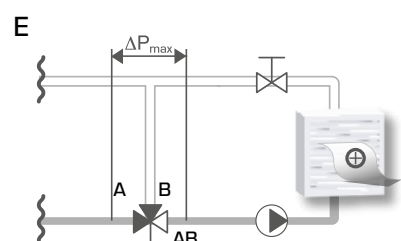

Circuit with local circulating pump